

Correvit® S-HR Sensors

Non-Contact Optical Sensors

Type CSHRA...

Patent No. 44 44 223 C5
DE 10 2007 008 004 B4

The Correvit S-HR sensors are an advancement of the proven 2-axis Correvit sensors and feature a high-resolution, low-noise angle signal.

- Correvit S-HR with working range 250 ±50 mm, applicable from 0,5 ... 250 km/h
- Accuracy of the unfiltered angle within the range of ±15 ° is ±0,1 °
- High-resolution slip angle measurement by enhanced measuring principle
- Adjustable filter time (unfiltered, moving average 8 ... 512 ms, FIR-Filter 2 ... 100 Hz)
- Extremely high measurement accuracy, better than ±0,2 %, as a result of precise optics and digital signal processing
- Signal outputs: Analog, Digital, CAN-Bus, USB, RS-232C



Description

Correvit S-HR sensors measure slip angle and sideslip angle with high dynamics and an exceptionally high measurement accuracy.

The patented enhancement of the well-known Correvit principle, the application of new optical components, and the latest technology in digital signal processing enable the most precise high-resolution slip angle measurement. True 250 Hz signal update rate tracks every high dynamic maneuver.

Due to the new operating principle (absolute measuring) the angle signal is very low-noise which provides maximum dynamic performance of the angle signal without further signal filtering. This advantage make the sensors especially suited for measuring transversal vehicle dynamics like sideslip angle but also tire slip angle when mounted on wheel.

The new Correvit S-HR sensors represent an essential contribution to the development of automotive measuring engineering.

Application

High-precision, slip-free measurement of distance, longitudinal/transversal speed and angle (high-resolution) for dynamic vehicle testing, e.g. ISO 4138 steady-state circular-course driving, ISO 7401 sudden steering angle change, tire research.

Technical Data

Performance Specifications

Speed range	km/h	0,5 ... 250
Angle measurement range	°	±40
High-resolution	°	±15
Distance resolution	mm	2,66
Measurement accuracy ¹⁾	%FSO	<±0,2
High-resolution angle output range	km/h	10 ... 250
Angle resolution	°	<0,01
Angle accuracy	°	<±0,1
Measurement frequency	Hz	250
Working distance and range	mm	250 ±50

Signal Outputs

Digital output 1 - IVI or V ²⁾	Pulse/m	1 ... 1 000/TTL
Digital output 2 - V _q or angle ²⁾	kHz	0 ... 46/TTL
Analog output 1 - IVI or V ²⁾	V	0 ... 10
Analog output 2 - V _q	V	-10 ... 10
Analog output 3 - angle	V	-10 ... 10

Signal Inputs

Trigger input		yes
Analog input 1+2	kHz	-10 ... 10
Counter input	kHz	0 ... 100

¹⁾ determined on test surface with distance >200 m

²⁾ Switching-over between the respective measured variables via CeCalWin Pro possible

Correvit® is a registered trademark of Kistler Holding AG

This information corresponds to the current state of knowledge. Kistler reserves the right to make technical changes. Liability for consequential damage resulting from the use of Kistler products is excluded.

Page 1/3

©2010 ... 2014, Kistler Group, Eulachstrasse 22, 8408 Winterthur, Switzerland
Tel. +41 52 224 11 11, Fax +41 52 224 14 14, info@kistler.com, www.kistler.com
Kistler is a registered trademark of Kistler Holding AG.

Technical Data (Continuation)

Interfaces

CAN (Motorola/Intel)		2.0B
USB (Full Speed)		2.0
RS-232C		yes

System Specifications

Power supply	V	10 ... 28
Power consumption at 12 V	W	60
Temperature range		
Operation (ambient temperature)	°C	-5 ... 50
Storage	°C	-10 ... 85
Relative Humidity (non-condensing)	%	5 ... 80
Degree of protection (cable mounted)		
Sensor head		IP67
Electronics		IP30
Dimensions (LxBxH)		
Sensor head	mm	165x50x130
Electronics	mm	180x125x95
Weight		
Sensor head (with spray guard)	grams	1 250
Electronics	grams	1 250
Shock	g	50 half-sine
	ms	6
Vibration	g	10
	Hz	10 ... 150
Illumination		halogen

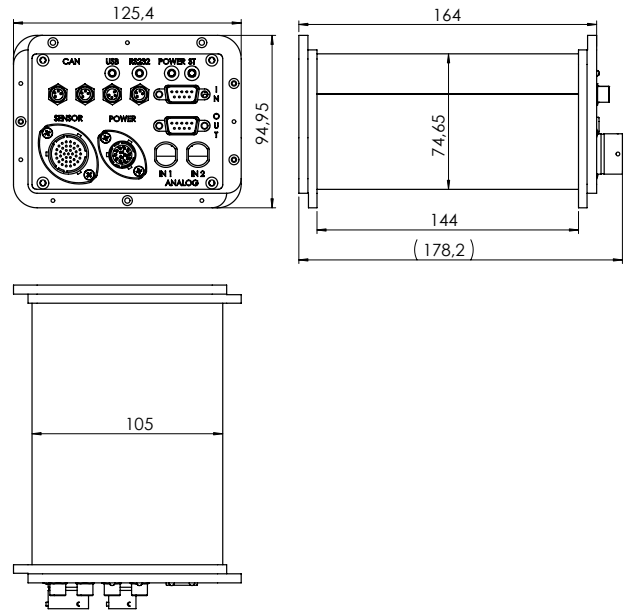

Fig. 2: Dimensions of Correvit® S-HR electronics

Dimensions

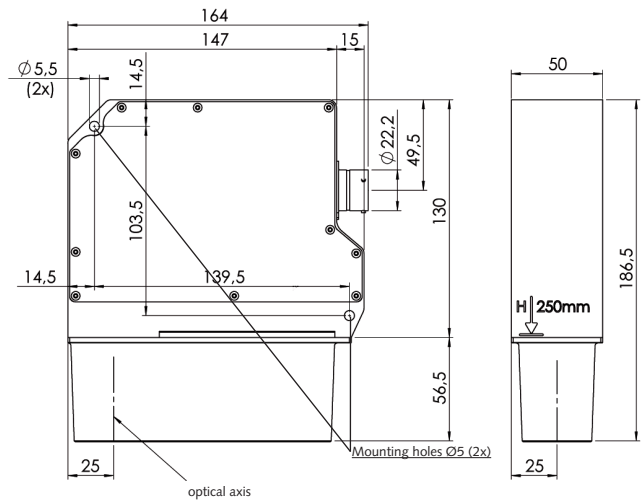

Fig. 1: Dimensions of Correvit® S-HR sensor

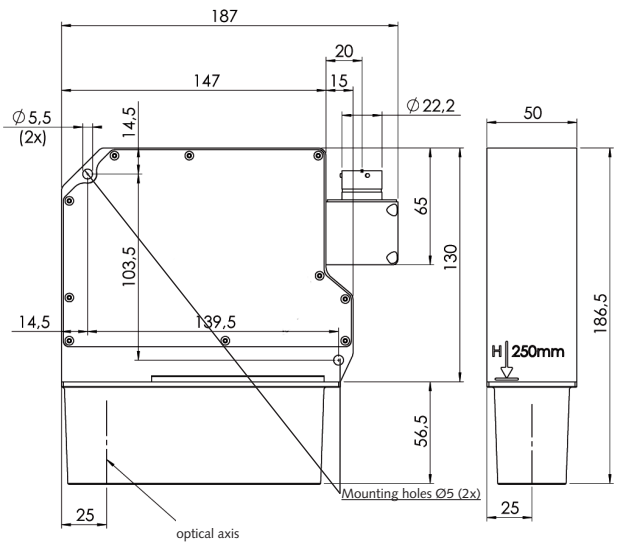

Fig. 3: Dimensions of Correvit® S-HR sensor with 90° connector

CSHRA_000-806e-04.14

Mounting

With Kistler mounting equipment (see Optional Accessories).

When mounting the sensor at the vehicle, the mounting distance from the lower surface of the sensor body (not including the spray guard) to the road must be 250 ± 50 mm.

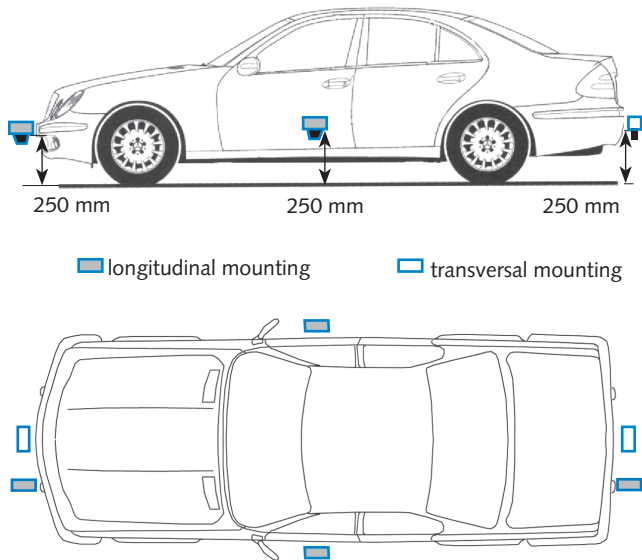

Fig. 4: Possible mounting positions

Ordering Key

		Type CSHRA	
Sensor Head			
Halogen*	2		
Sensor Cable			
2 m	1		
5 m*	2		
10 m	3		
Electronics			
Standard*	1		
Interface Outputs			
± 10 V*	1		
± 5 V	2		
Mounting Directions			
Longitudinal*	1		
Transversal	2		
Longitudinal with 90° connector	3		
Transversal with 90° connector	4		
Interface Inputs			
± 10 V*	1		

Included Accessories

- Power cable, l = 2 m
- Connection cable CAN, l = 2 m
- Connection cable RS-232C, l = 2 m
- Connection cable USB, l = 2 m
- Distribution cable, l = 1 m
- Transport case S-HR, complete
- Mini folding rule
- Multimedia-CD incl. Software & Manuals
- Sensor calibration
- Halogen lamp 20 W/12 V
- Tool to exchange the sensor halogen lamp
- Cranked wrench key
- Hexagon wrench key, 6 kt 4 mm
- Screw set S-HR
- Spray guard

Ordering No.

- 18012634
- 18012482
- 18012469
- 18012483
- 55061503
- 55066885
- 55064207
- 55082182
- 44000659
- 18012531
- 55064735
- 55065040
- 55063983
- 55085761
- 18012623

Optional Accessories

- Suction holder S-HR
- Magnet holder S-HR

Ordering No.

- 18012622
- 18012621

Ordering Example*

Type CSHRA22111

S-HR sensor, standard halogen illumination, 5 m cable, standard electronics, interface outputs ± 10 V, longitudinal mounting direction, interface inputs ± 10 V

* Standard configuration