

Miniature Force Sensor

Type 9210AA...

for Mold Cavity Pressure with Diameter $\varnothing 3,5$ mm

Introduction

Quartz crystal force sensor for a measuring range from 0 to 250 N or for measurement of internal pressure up to 3 000 bar during the injection molding of plastics.

- Minimum size for installation in a mold insert
- Ideal for multi-cavity applications
- Indirect measurement via a measuring pin

Description

This miniature version of the sensor 9210AA... measures the mold cavity pressure via a measuring pin. This pressure value is obtained from the force measured divided by the area of the measuring pin used. The integral single-wire cable with a very small cross-sectional area is designed to allow flexibility of mounting. With the single-wire technique, electrical shielding is guaranteed by the mold. It is therefore essential for the cable and connector to be integrated in the mold.

The charge signal (pC = picocoulomb) produced by the force sensor is converted into a proportional output voltage in a charge amplifier or a monitor. The maximum possible output voltage at the standard amplifier is 10 V, which corresponds to the maximum pressure value depending on the measuring pin area.

For multi-cavity applications the sensor Type 9210AAG without connector is used. The multichannel connectors Type 1708A... and 1710A... connect up to 4, respectively 8 sensors.

Application

The sensor is primarily suitable for industrial applications in optimising, monitoring and controlling injection molding of thermoplastics.

The miniature sensor has been specially developed for mounting in multi-cavity molds where there is limited space. The sensor can be mounted directly under a mold insert by means of the lateral cable outlet. At the side, the sensor is secured via the case against rotation. Mounting is facilitated by using a measuring pin (for example a standart ejector pin). The pin can be adapted in situ to any cavity.

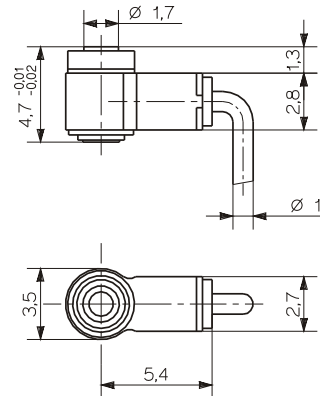

Technical Data

Measuring range	N	0 ... 250
Overload	N	300
Sensitivity	pC/N	-11
Linearity	%FSO	$\leq \pm 1$
Operating temperature range	°C	0 ... 200
Insulation resistance		
at 20 °C	Ω	$\geq 10^{13}$
at 120 °C	Ω	$\geq 10^{12}$

Cable and Amplifier for Measuring Chain with Sensor Type 9210AA...

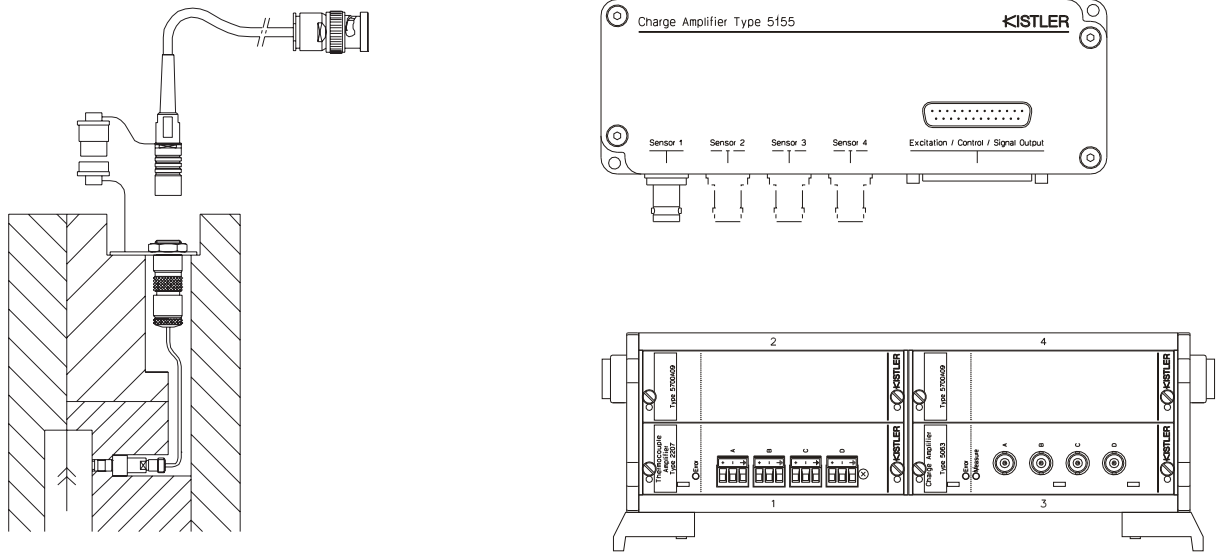

Cable Type 1667B... or 1661A... (BNC connector)	Cable Type 1672B... or 1662A... (TNC connector)
Type 5039Axx2	Type 5039Axx1
Type 5049Axx2	Type 5049Axx1
Type 5155Axx2x/Axx4x/Axx8x	Type 5155Axx1x/Axx3x/Axx7x
Type 5063A1 in Type 2853A.../2859A.../2865A.../2865B...	

Fig. 1: Sensor Type 6183A... with Charge Amplifier Typ 5155A... or Signal Conditioner Type 2859/2865...

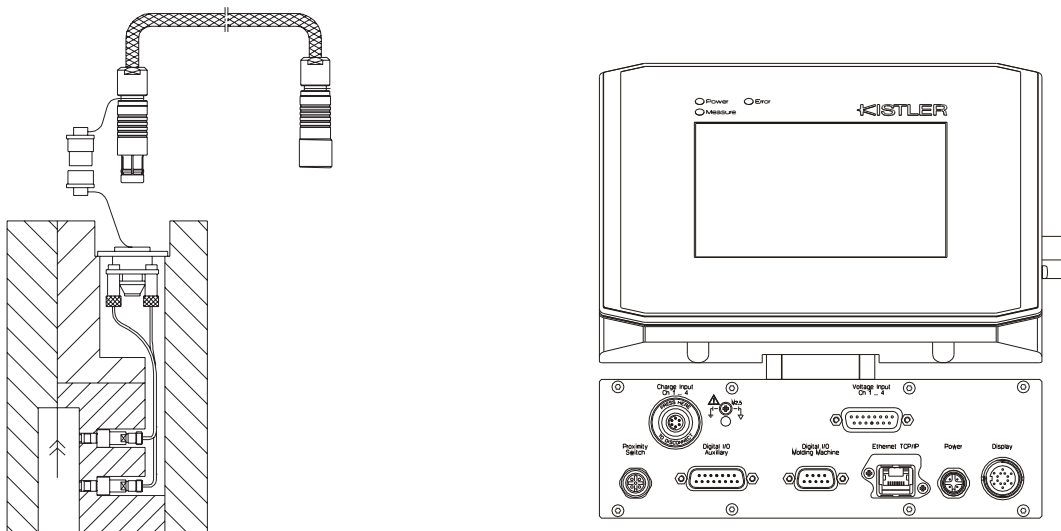

4-channel cable Type 1995A... to connector Type 1708A..	8-channel cable Type 1997A... on connector Type 1710A...
Type 2869A0xx	Type 2869A2xx/2869B2xx
Type 2869A1xx/2869B1xx	Type 2869B3xx

Fig. 2: Sensor Type 6183A... with Monitoring System CoMo Injection Type 2869...

9210AA_000-601e-11.09

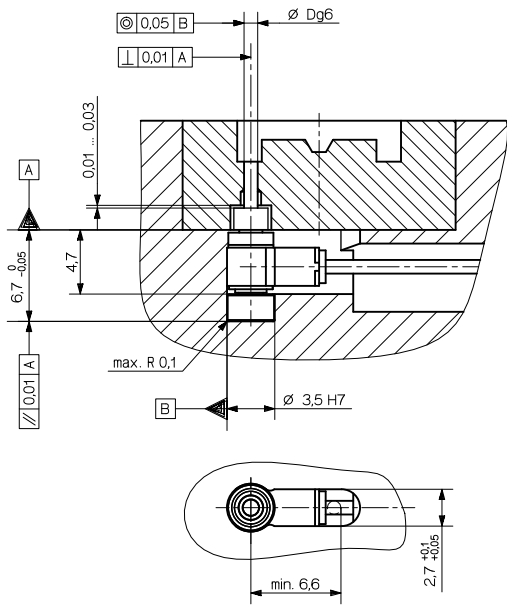

Fig. 3: Mounting in blind hole with measuring pin and hardened thrust washer $\varnothing 3,5$ mm Type 9406

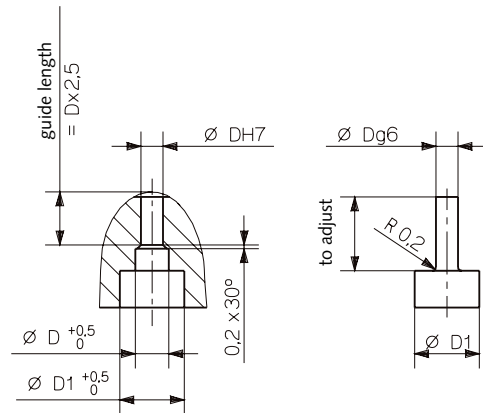

Fig. 4: Hole and dimensions of the measuring pin

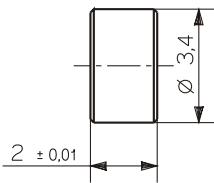

Fig. 5: Thrust washer Type 9406

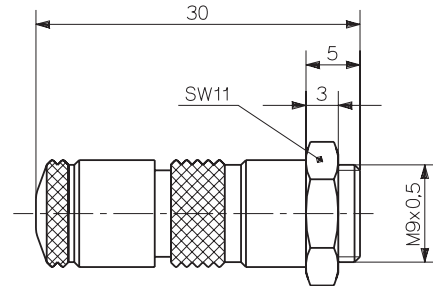

Fig. 6: Connector Type 1839

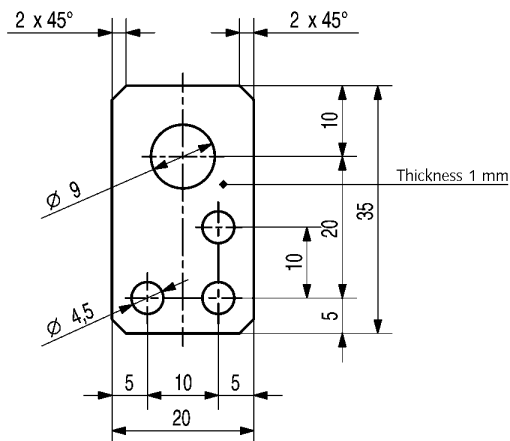

Fig. 7: Mounting plate (Art. No. 3.520.328)

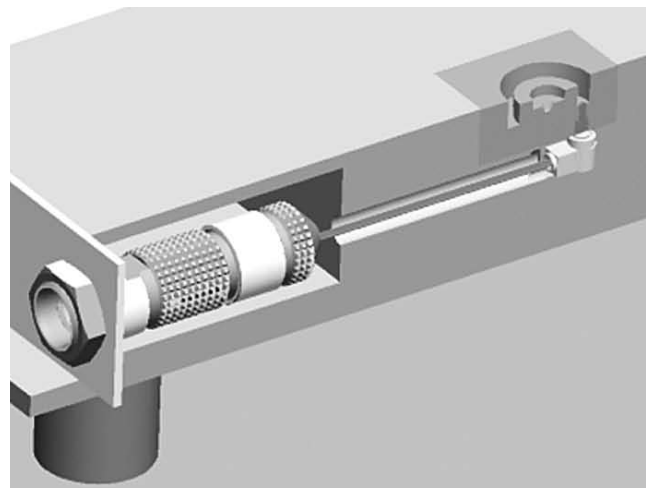

Fig. 8: Installation with sensor, measurement pin, cable, connector and mounting plate

Calculation of Sensitivity for Pressure Measurement

When mounting the force sensor for pressure measurement, the front area of the measuring pin must be considered. The nominal sensor sensitivity (pC/N) is converted into a corresponding pressure sensitivity using the following formula.

$$\text{Calculated pressure sensitivity [pC/bar]} = \frac{\text{Nominal force sensitivity [pC/N]} \cdot \text{area of the ejector pin [mm}^2\text{]}}{0,1}$$

The measuring range of the sensor must be taken into account when selecting the measuring pin. The larger the area of the measuring pin, the higher will be the force on the sensor.

The following table shows the calculated sensitivity with the nominal sensitivity of Type 9210AA... and the maximum pressure for selecting the measuring pin.

Measuring Pin Diameter [mm]	Sensitivity [pC/bar]	Maximum Pressure [bar]
1,0	-0,82	3 000
1,2	-1,18	2 500
1,4	-1,61	1 800
1,6	-2,11	1 400
1,8	-2,67	1 100
2,0	-3,29	900
2,2	-3,99	750

Mounting

The miniature force sensor has a very finely ground front face. The contact surface of the measuring pin should also be finely machined, flat, rigid and exactly parallel. The hardened thrust washer Type 9406 supplied should be used when mounting have in a blind hole. When selecting a measuring pin, a normal commercial injector pin can be used. When mounted, the sensor must not have any preload. The measuring pin must be installed with a clearance of from 0,01 to 0,03 mm (Fig. 3).

The single-wire cable must be installed completely in the mold. The connector supplied must be mounted with the single-wire cable cut to size but with its insulation intact. This is then inserted with the mounting plate in the mold and secured. The nameplate should also be affixed alongside it giving details of the type of sensor and its sensitivity.

Accessories Included

- Thrust washer
- Connector with short-circuit cap
- Mounting plate
- Identification plate

Type/Art. No.

- 9406
- 1839
- 3.520.328
- 3.520.842

Optional Accessories

- 4-Channel connector
- 8-Channel connector

- 1708A...
- 1710A...

Ordering Key

Sensor with single-wire cable	E
Length 1,5 m with connector	
Sensor Type 9210AAE	G
Without connector	

Type 9210AA



9210AA_000-601e-11.09

Miniature Force Sensor

Type 9213B...

for Mold Cavity Pressure with diameter 6 mm and M2,5 thread

Quartz force sensor for the measuring range from 0 ... 2 500 N or for measuring mold cavity pressure of up to >3 000 bar during injection molding of plastics.

- Case with M2,5 mounting thread
- Replaceable cable
- Available with singlewire technology

Description

The Type 9213B... miniature sensor offers high resolution and has extremely small dimensions and a rugged, welded case. The charge signal (pC = pico coulombs) output by the force sensor is converted in the Kistler charge amplifier or in a monitoring unit into a proportional output voltage that is largely independent of the length of the sensor cable. The maximum possible output voltage from the standard amplifier is 10 V. In the most sensitive range this gives 1 N/V. The replaceable cables allow a wide choice of connecting cables, including the singlewire version. With singlewire technology an individual cable is shortened to the required length and connected to the connector using the proven cut and grip technique. With this arrangement the mold serves as a shield for signal transmission.

For multi cavity applications the sensor Type 9213B... is used without the singlewire connector Typ 1839. For 4-channel applications the Sensor Type 9213B... is mounted with the Multi-Channel Connector Type 1708... and for 8-channel applications with the Multi-Channel Connector Type 1710...

Application

Thanks to its compactness the miniature force sensor is suitable for dynamic and quasistatic force measurements. This is particularly useful for an application like injection molding, where space is critical and forces are high. Indirect pressure measurement is particularly suitable for molds with small cavities or a large number of ejectors. The sensor is positioned under the ejector pin in the ejector plate, and measures the force curve by means of the ejector. This allows calculation of the actual mold cavity pressure.

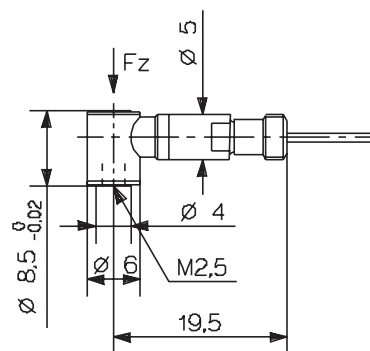

Technical Data

Measuring range	N	0 ... 2 500
Calibrated partial range	N	0 ... 250
Overload	N	3 000
Threshold	mN	10
Sensitivity	pC/N	-4,4
Linearity, all ranges	%FSO	≤±1
Operating temperature range	°C	-40 ... 200
Insulation resistance		
at 20 °C	Ω	≥10 ¹³
at 120 °C	Ω	≥10 ¹²

Force Sensor Type 9213BE

Indirect measuring sensor with replaceable singlewire cable.
Suitable for mounting as complete module in the ejector plate.

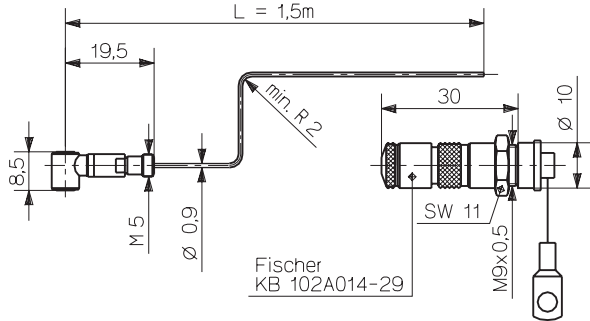

Fig. 1: Force Sensor Type 9213BE with cable and connector

Force Sensor Type 9213Bsp with standard lengths 0,2/0,4/0,6/0,8/1,2 m

Indirect measuring sensor with replaceable coaxial connecting cable in lengths of 0,2/0,4/0,6/0,8/1,2 m or special lengths.

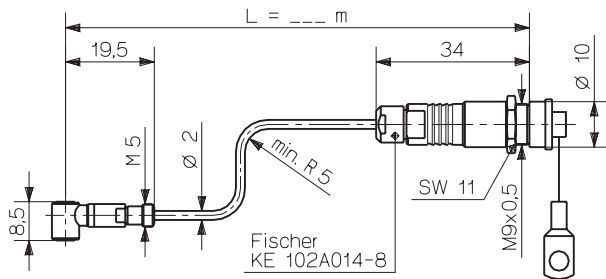

Fig. 2: Force Sensor Type 9213Bsp with cable and connector (standard length: 0,2/0,4/0,6/0,8/1,2 m)

Computation of Sensitivity for the Pressure Measurement

The front face of the ejector pin must be taken into account when mounting the force sensor for pressure measurement. The nominal sensor sensitivity (pC/N) is converted into a corresponding pressure sensitivity using the following formula.

$$\text{Calculated pressure sensitivity [pC/bar]} = \text{Nominal force sensitivity [pC/N]} \cdot \text{area of ejector pin [mm}^2\text{]} \cdot 0.1$$

The measuring range of the sensor must be taken into account when choosing the ejector pins. The larger the ejector pin area the higher the force on the sensor.

The following table shows the calculated sensitivity with the nominal sensitivity of the Type 9213B... and the maximum pressure for a selection of ejector pins.

Diameter ejector pin [mm]	Sensitivity [pC/bar]	Maximum pressure [bar]
1,6	-0,88	>3 000
2	-1,38	
2,5	-2,16	
3	-3,11	
4	-5,53	2 000
5	-8,64	1 250

Mounting

The miniature force sensor has a precision ground face. The bearing surface of the ejector pin must also be finely machined, flat, rigid and exactly parallel. A hardened thrust washer must be used when mounting in a blind hole. The sensor can be mounted from below with an M2,5 screw. Once mounted the sensor must not have any preload. A clearance of 0.03mm is recommended.

When using the singlewire technology, it must be ensured that the single-wire cable is kept in the ejector plate and that the Type 1839 connector is also mounted in this plate. When installing the connector in a different plate, electrical shielding by the mold must be ensured.

Principle of Mounting

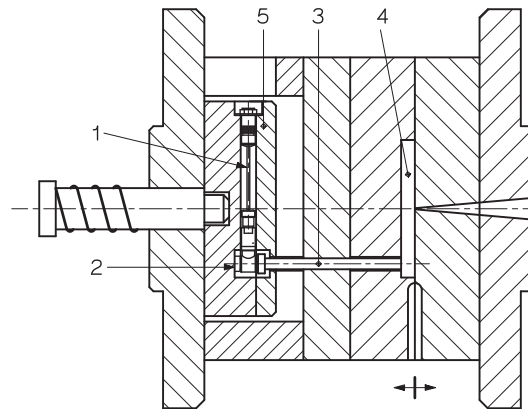

- 1 Force sensor
- 2 Thrust washer
- 3 Ejector pin
- 4 Cavity
- 5 Ejector plate

Fig. 3: Force sensor for indirect measurement of mold cavity pressure behind an ejector pin in the mold.

9213B-000-556e-01.15

Cable and Amplifier for Measuring Chains with Sensor Type 9213B...

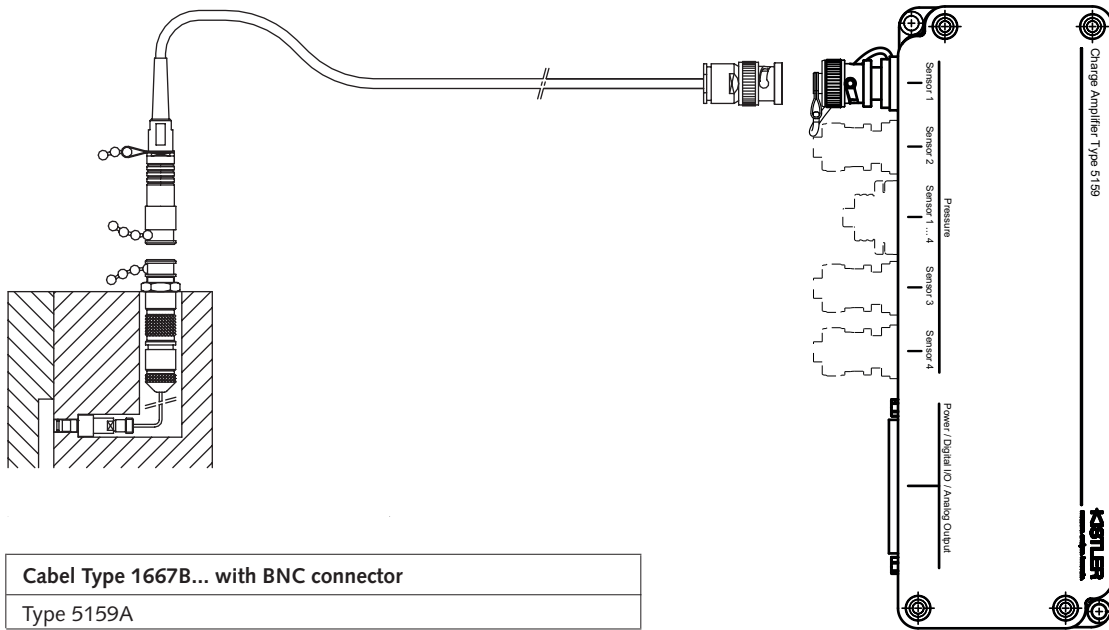

Fig. 4: Sensor Type 9213B... with charge amplifier Type 5159A...

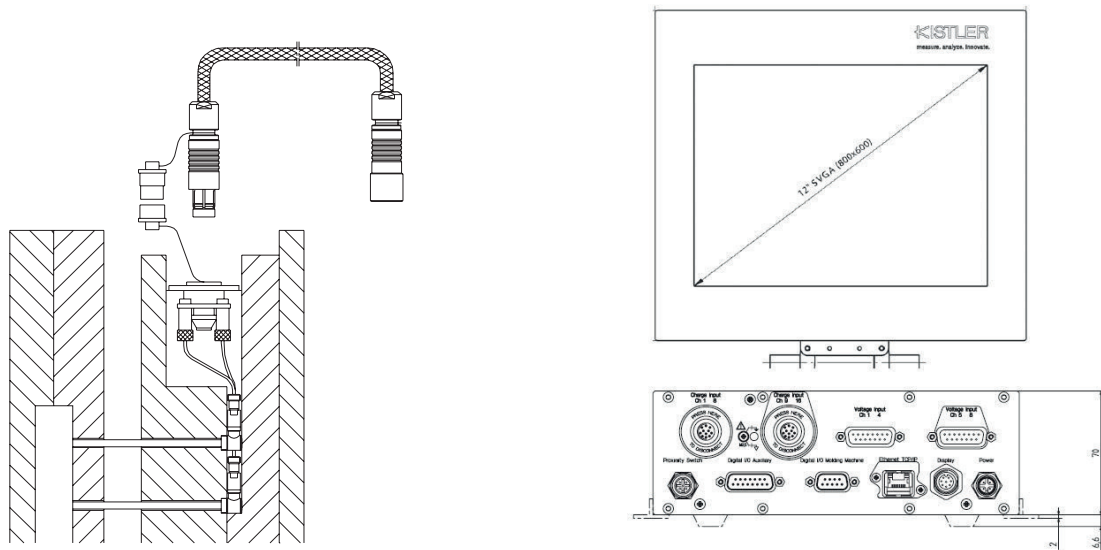

Fig 5: Sensor Type 9213B... with monitoring system CoMo® Injection Type 2869B...

9213B-000-556e-01.15

Mounting Examples

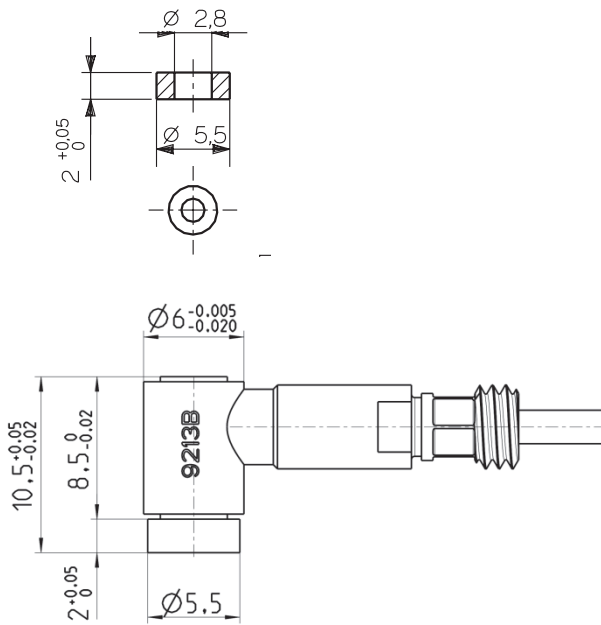

Fig. 6: Sensor Type 9213 with thrust washer Type 9413

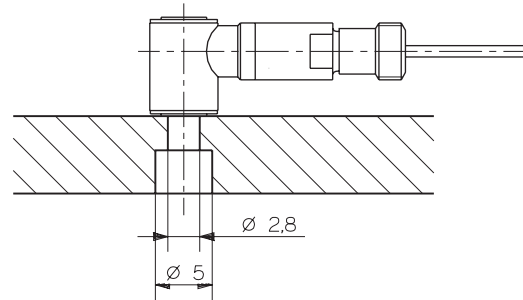

Fig. 7: Mounting in retaining plate

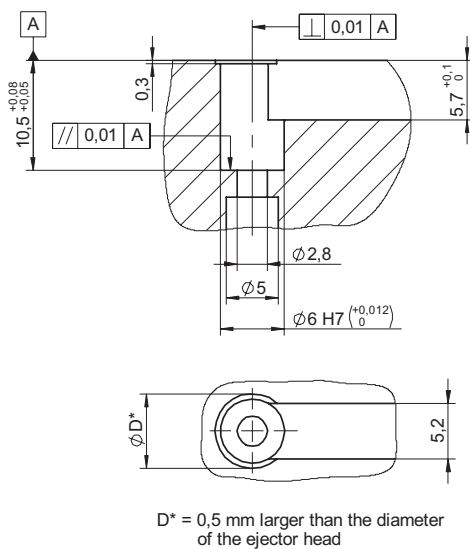
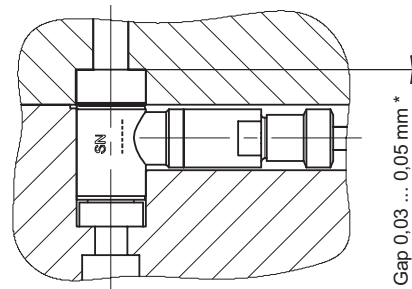

Fig. 8: Mounting bore with thrust washer Type 9413



* Sensor should not be preloaded. Consider this value as a minimum during construction and realisation of the mold. Depending on deformation, it could be necessary to have a bigger gap. Check clearance before mounting the sensor.

Fig. 9: Mounting sensor Type 9213 with ejector pin

9213B-000-556e-01.15

Accessories Included

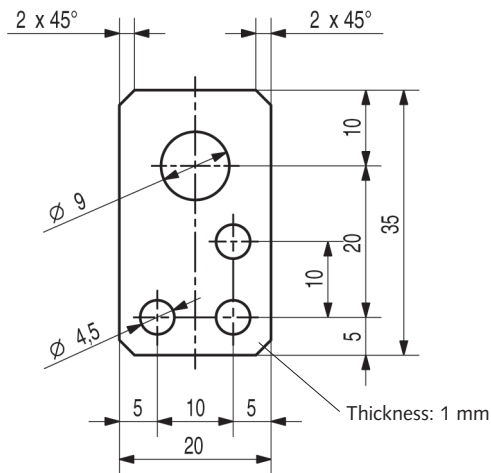

Fig. 10: Mounting plate Art. No. 3.520.328

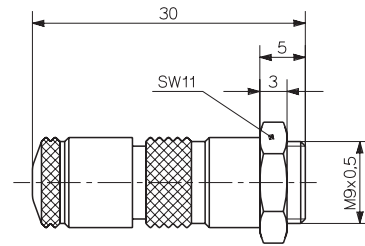

Fig. 11: Singlewire connector Type 1839

Accessories Included

Miniature force sensor Type 9213BE with singlewire cable

- Connector
- Mounting plate
- Thrust washer
- Identification plate

Type/Art. No.

- 1839
- 3.520.328
- 9413
- 3.520.235

High temperature extension cable with metal tubing and BNC connection

- Length 2 m 1661A2
- Length 5 m 1661A5
- Length 10 m 1661A10
- Special length (between 0,5 m and 8 m) 1661A sp
- 4-channel connector 1708
- 8-channel connector 1710

Miniature force sensor Type 9213Bsp (standard lengths: 0,2/0,4/0,6/0,8/1,2 m) with coaxial cable and connector

- Mounting plate
- Thrust washer
- Identification plate

- 3.520.328
- 9411
- 3.520.235

Optional Accessories

High temperature extension cable Fluoropolymer with BNC connection

- Length 2 m
- Length 5 m
- Length 10 m
- Special length (between 0,5 m and 8 m)

Type/Art. No.

- 1667B2
- 1667B5
- 1667B10
- 1667Bsp

Ordering Key

Singlewire cable, L = 1,5 m	E
Coaxial cable with special length, specify cable length L in m (L _{min} = 0,1 m / L _{max} = 5 m*)	sp
Sensor Type 9213BE without connector	G

* Standard lengths: 0,2/0,4/0,6/0,8/1,2 m

Type 9213B



9213B-000-556e-01.15

Miniature Force Sensor

Type 9211B...

for Mold Cavity Pressure with diameter 6 mm

Quartz force sensor for the measuring range from 0 ... 2 500 N or for measuring mold cavity pressure of up to >3 000 bar during injection molding of plastics.

- Extremely compact
- Replaceable cable
- Available with single-wire technology

Description

The 9211B... miniature sensor offers high resolution and has extremely small dimensions and a rugged, welded case. The charge signal (pC = pico coulombs) output by the force sensor is converted in the Kistler charge amplifier or in a monitoring unit into a proportional output voltage that is largely independent of the length of the sensor cable. The maximum possible output voltage from the standard amplifier is 10 V. In the most sensitive range this gives 1 N/V. The replaceable cables allow a wide choice of connecting cables, including the single-wire version. With single-wire technology an individual cable is shortened to the required length and connected to the connector using the proven cut and grip technique. With this arrangement the mold serves as a shield for signal transmission.

For multi cavity applications the sensor Type 9211B... is used without the single-wire connector Typ 1839. For 4-channel applications the Sensor Type 9211B... is mounted with the Multi-Channel Connector Type 1708... and for 8-channel applications with the Multi-Channel Connector Type 1710...

Application

Thanks to its compactness the miniature force sensor is suitable for dynamic and quasistatic force measurements. This is particularly useful for an application like injection molding, where space is critical and forces are high. Indirect pressure measurement is particularly suitable for molds with small cavities or a large number of ejectors. The sensor is positioned under the ejector pin in the ejector plate, and measures the force curve by means of the ejector. This allows calculation of the actual mold cavity pressure.

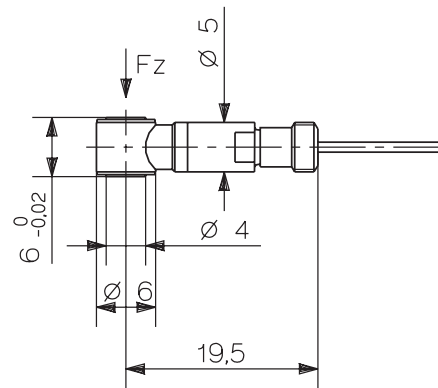

Technical Data

Measuring range	N	0 ... 2 500
Calibrated partial range	N	0 ... 250
Overload	N	3 000
Threshold	mN	10
Sensitivity	pC/N	-4,4
Linearity, all ranges	%FSO	≤±1
Operating temperature range	°C	-40 ... 200
Insulation resistance		
at 20 °C	Ω	≥10 ¹³
at 120 °C	Ω	≥10 ¹²

Force Sensor Type 9211BE

Indirect measuring sensor with replaceable single-wire cable. Suitable for mounting as complete module in the ejector plate.

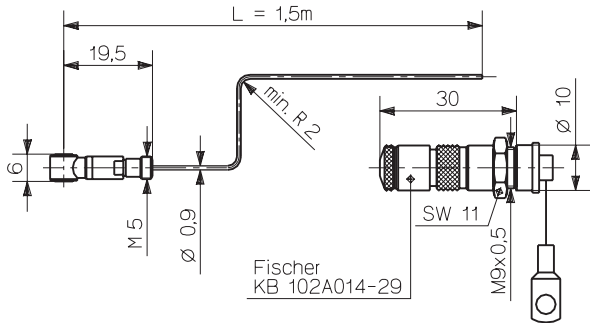

Fig. 1: Force Sensor Type 9211BE with cable and connector

Force Sensor Type 9211Bsp with standard lengths 0,2/0,4/0,6/0,8/1,2 m

Indirect measuring sensor with replaceable coaxial connecting cable in lengths of 0,2/0,4/0,6/0,8/1,2 m or special lengths.

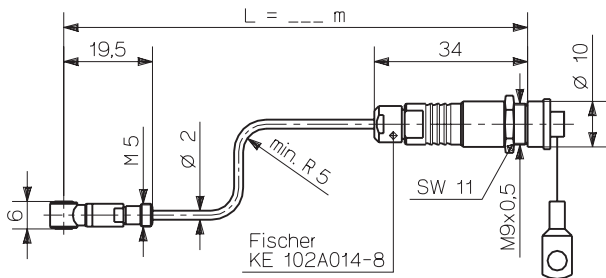

Fig. 2: Force Sensor Type 9211Bsp with cable and connector (standard length: 0,2/0,4/0,6/0,8/1,2 m)

Computation of sensitivity for the pressure measurement

The front face of the ejector pin must be taken into account when mounting the force sensor for pressure measurement. The nominal sensor sensitivity (pC/N) is converted into a corresponding pressure sensitivity using the following formula.

$$\text{Calculated pressure sensitivity [pC/bar]} = \frac{\text{Nominal force sensitivity [pC/N]} \cdot \text{area of ejector pin [mm}^2\text{]} \cdot 0,1}{\text{area of ejector pin [mm}^2\text{]}}$$

The measuring range of the sensor must be taken into account when choosing the ejector pins. The larger the ejector pin area the higher the force on the sensor.

The following table shows the calculated sensitivity with the nominal sensitivity of the Type 9211B... and the maximum pressure for a selection of ejector pins.

Diameter ejector pin [mm]	Sensitivity [pC/bar]	Maximum pressure [bar]
1,6	-0,88	>3 000
2	-1,38	
2,5	-2,16	
3	-3,11	2 000
4	-5,53	
5	-8,64	1 250

Mounting

The miniature force sensor has a precision ground face. The bearing surface of the ejector pin must also be finely machined, flat, rigid and exactly parallel. A hardened thrust washer must be used when mounting in a blind hole. Once mounted the sensor must not have any preload. A clearance of 0,03mm is recommended.

When using the single-wire technology, it must be ensured that the single-wire cable is kept in the ejector plate and that the Type 1839 connector is also mounted in this plate. When installing the connector in a different plate, electrical shielding by the mold must be ensured.

Principle of Function

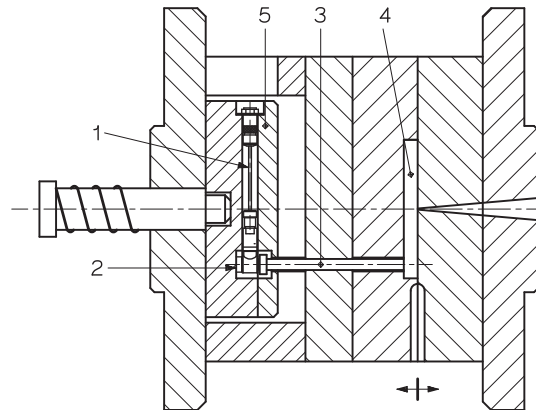

- 1 Force sensor
- 2 Thrust washer
- 3 Ejector pin
- 4 Cavity
- 5 Ejector plate

Fig. 3: Force sensor for indirect measurement of mold cavity pressure behind an ejector pin in the mold.

9211B_000-555e-01_15

Cable and Amplifier for Measuring Chains with Sensor Type 9211B...

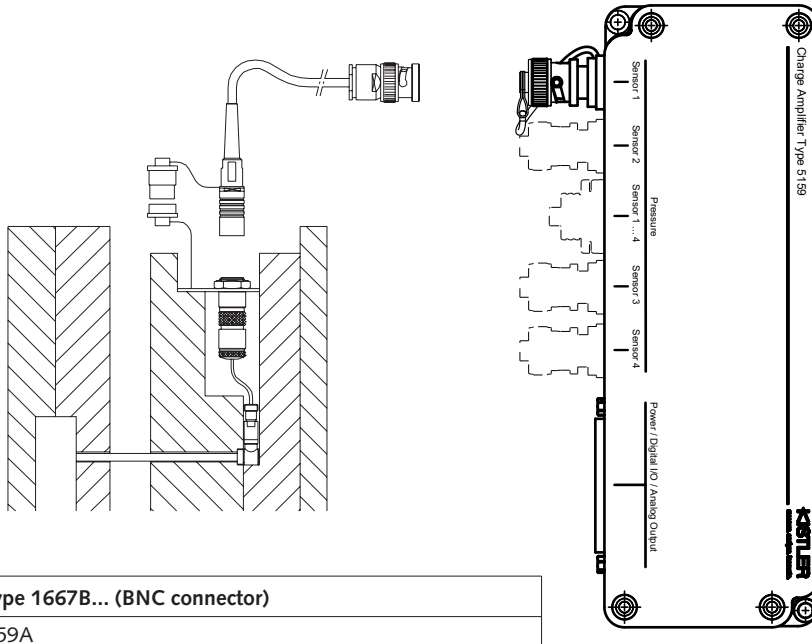

Cabel Type 1667B... (BNC connector)
Type 5159A

Fig. 4: Sensor Type 9211B... with charge amplifier Typ 5159A

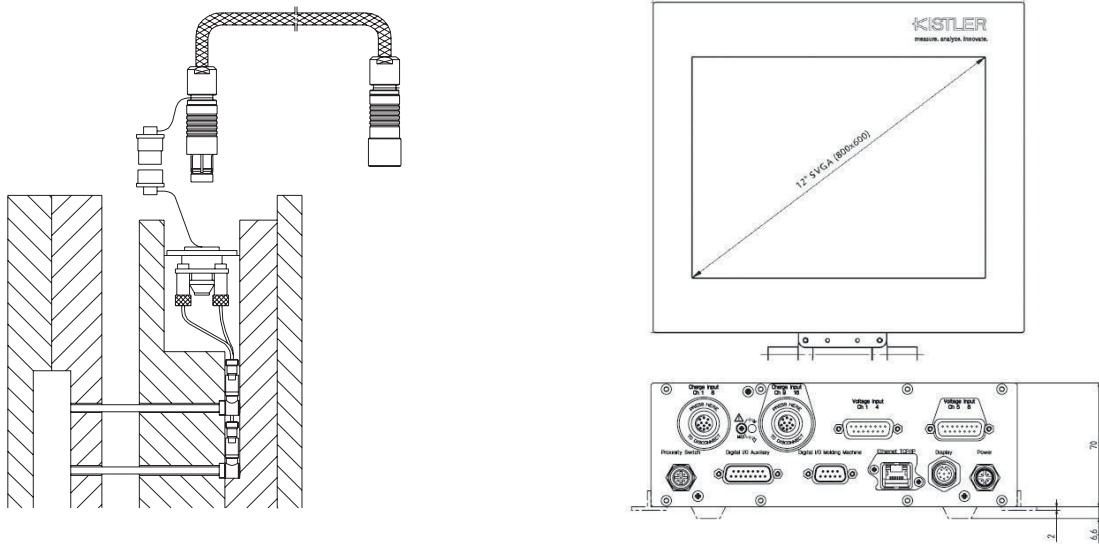

4-Channel Cable Type 1995A... to Connector Type 1708	8-Channel Cable Type 1997A... to Connector Type 1710
Type 2869B0xx	Type 2869B2xx
Type 2869B1xx	Type 2869B3xx

Fig 5: Sensor Type 9211B... with monitoring system CoMo® Injection Type 2869B...

9211B_000-555e-01 .15

Mounting Examples

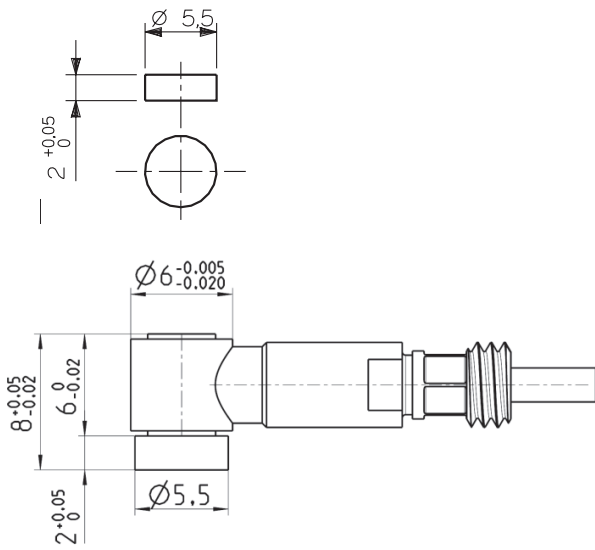

Fig. 6: Sensor Type 9211 with thrust washer Type 9411

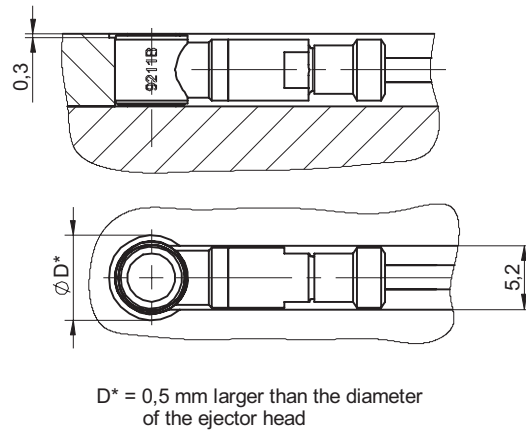

Fig. 7: Mounting in retaining plate

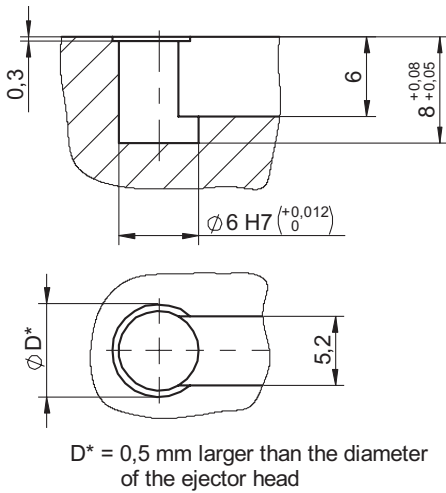
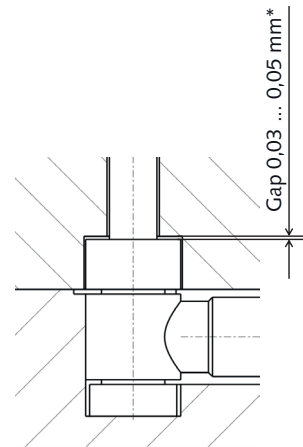

Fig. 8: Mounting bore with thrust washer Type 9411



* Sensor should not be preloaded. Consider this value as a minimum during construction and realisation of the mold. Depending on deformation, it could be necessary to have a bigger gap. Check clearance before mounting the sensor.

Fig. 9: Mounting sensor Type 9213 with ejector pin

9211B_000-555e-01_15

Accessories included

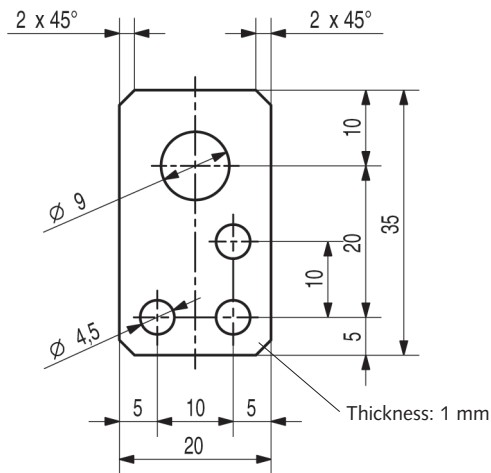

Fig. 10: Mounting plate Art. No. 3.520.328

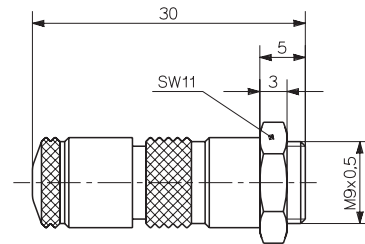

Fig. 11: Single-wire connector Type 1839

Accessories Included

Miniature force sensor Type 9211BE with single-wire cable

- Connector
- Mounting plate
- Thrust washer
- Identification plate

Type/Art. No.

- 1839
- 3.520.328
- 9411
- 3.520.235

High temperature extension cable with metal tubing and BNC connector

- Length 2 m 1661A2
- Length 5 m 1661A5
- Length 10 m 1661A10
- Special length (between 0,5 m and 8 m) 1661Aasp
- 4-channel connector 1708
- 8-channel connector 1710

Miniature force sensor Type 9211Bsp (standard lengths: 0,2/0,4/0,6/0,8/1,2 m) with coaxial cable and connector

- Mounting plate
- Thrust washer
- Identification plate

- 3.520.328
- 9411
- 3.520.235

Optional Accessories

High temperature extension cable Fluoropolymer with BNC connector

- Length 2 m
- Length 5 m
- Length 10 m
- Special length (between 0,5 m and 8 m)

Type/Art. No.

- 1667B2
- 1667B5
- 1667B10
- 1667Bsp

Ordering Key

Single-wire cable, L = 1,5 m	E
Coaxial cable with special length, specify cable length L in m (L _{min} = 0,1 m / L _{max} = 5 m*)	sp
Sensor Type 9211BE without connector	G

Type 9211B

* Standard lengths: 0,2/0,4/0,6/0,8/1,2 m

9211B_000-555e-01_15

PinSens Kraftsensor für die indirekte Werkzeuginnendruckmessung
PinSens le capteur de force pour la mesure indirecte de la pression dans l’empreinte.
PinSens force sensor for indirect mold cavity pressure measurement

9204B...

Kraftsensor zur indirekten Werkzeuginnen-druckmessung hinter einem Mess- oder Auswerferstift.

Capteur de force pour la mesure de la pression dans l’empreinte au moyen d’une tige de mesure ou d’éjection.

Force sensor for indirect mold cavity pressure measurement behind a measuring or ejector pin.

- Auswechselbares Hochtemperatur-Kabel mit «Fischer»-Stecker
 Câble à haute température échangeable avec connecteur «Fischer»
 Interchangeable high temperature cable with «Fischer» connector
- Einfache Konstruktion und Handhabung
 Construction simple et manipulation aisée
 Simple design and handling

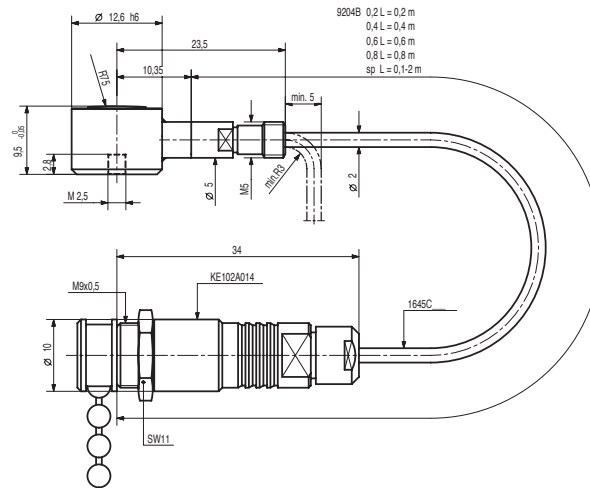

Technische Daten

Données techniques

Technical Data*

Bereich	Gamme	Range	kN	10
Überlast	Surcharge	Overload	kN	12
Empfindlichkeit	Sensibilité	Sensitivity	pC/N	-1,6
Linearität	Linéarité	Linearity	% FSO	±2
Steifheit, Mittelwert	Rigidité valeur moyenne	Rigidity mean value	N/μm	160
Eigenfrequenz	Fréquence propre	Natural frequency	kHz	≈80
Betriebstemperaturbereich	Gamme de tempér. d'utilisation	Operating temperature range	°C	-50 ... 200
Temperaturkoeffizient der Empfindlichkeit	Coefficient de température de la sensibilité	Temperature coefficient of sensitivity	%/°C	-0,02
Kapazität	Capacité	Capacitance	pF	16
Isolationswiderstand der Empfindlichkeit	Résistance d'isolement de la sensibilité	Insulation resistance of sensitivity	TΩ	>1
			TΩ	>10

1 N (Newton) = 1 kg·m·s⁻² = 0,1019... kp = 0,2248... lbf; 1 kp = 1 kgf = 9,80665 N; 1 inch = 25,4 mm; 1 kg = 2,2046... lb; 1 Nm = 0,73756... lbft

* In all Kistler documents, the decimal sign is a comma on the line (ISO 31-0:1992).

Die vom Sensor abgegebene elektrische Ladung (Pc = Picocoulomb) wird durch den Kistler Ladungsverstärker in eine proportionale Spannung von 0 ... 10 V DC umgewandelt. Die Länge des Sensorkabels hat keinen Einfluss.

La charge électrique produite par le capteur (en Pc = picocoulomb) est transformée par l'amplificateur Kistler en une tension proportionnelle de 0 à 10 V CC. La longueur du câble du capteur n'a aucune influence.

The electric charge from the sensor (pC = picocoulomb) is converted by the Kistler charge amplifier into a proportional voltage of 0 ... 10 V DC. The length of the sensor cable has no influence.

Beschreibung

PinSens Typ 9204B... ist ein einfach aufgebauter Kraftsensor für die indirekte Werkzeuginnendruckmessung hinter einem Mess- oder Auswerferstift. Dabei muss der Durchmesser des Mess- bzw. Auswerferstiftes bei der Umrechnung von Kraft auf Druck berücksichtigt werden.

Description

PinSens de type 9204B... est un capteur de conception simple pour la mesure de la pression dans l'empreinte au moyen d'une tige de mesure ou d'éjection. Son diamètre doit être pris en considération pour la conversion de la pression en force.

Description

PinSens Type 9204B... is a simply constructed force sensor for indirect mold cavity pressure measurement behind a measuring or ejector pin. The diameter of the measuring or ejector pin must be taken into account in the conversion from force to pressure.

Die Aussenabmessungen entsprechen den üblichen 1/2" x 3/8" Einbaunuten. Der Sensor kann mit der mitgelieferten Schraube befestigt werden.

Les dimensions extérieures correspondent à celles des rainures d'insertion (1/2" x 3/8"). Le capteur peut être fixé au moyen de la vis livrée avec lui.

The outer dimensions correspond to the usual 1/2" x 3/8" mounting grooves. The sensor can be secured with the screw supplied.

000-128m-02.02 (DB06.9204Bm)

Anwendung

Während der Werkzeuginnendruck in industriellen Anwendungen in der Regel direkt in der Werkzeugkavität gemessen wird, gibt es Situationen, in denen dies z.B. aus Platzgründen nicht möglich ist.

PinSens ist eine kostengünstige Alternative für diese Fälle.

Lieferumfang

	Art.Nr.
Montageplatte	3.520.328
Zylinderschraube	6.120.166
Federring	6.230.049

Zubehör

Typ	
Hochtemperatur-Verlängerungskabel mit Stahlgeflecht ummantelt Fischer SE102A014-TNC pos.	
Länge 2 m	1672A2
Länge 5 m	1672A5
Hochtemperatur-Verlängerungskabel Teflon Fischer SE102A014-BNC pos.	
Länge 2 m	1667A2
Länge 5 m	1667A5
Klemmstück für Stecker	1401

Umrechnungstabelle

Gerechnet mit der nominellen Empfindlichkeit von 1,6 pC/N

Formel:

Auswerferstift – Fläche [mm²] x 0,1 x Sensor-empfindlichkeit [pC/N]

Formule:

Tige d'éjection – surface [mm²] x 0,1 x sensibilité du capteur [pC/N]

Formula:

Ejector pin - area [mm²] x 0,1 x sensor sensitivity [pC/N]

Applications

Dans les applications industrielles, on mesure la plupart du temps la pression à l'intérieur de l'empreinte directement dans la cavité, il est des situations dans lesquelles ce n'est pas possible pour diverses raisons (manque de place, par exemple).

PinSens constitue une alternative avantageuse dans ces cas.

Etendue de la fourniture

	Art.No.
Plaque de montage	3.520.328
Vis cylindrique	6.120.166
Rondelle ressort	6.230.049

Accessoires

Type	
Câble de rallonge à haute température avec protection en acier tressé Fischer SE102A014-TNC pos.	
Longueur 2 m	1672A2
Longueur 5 m	1672A5
Câble de rallonge à haute température au Téflon Fischer SE102A014-BNC pos.	
Longueur 2 m	1667A2
Longueur 5 m	1667A5
Bride pour le connecteur	1401

Table de conversion

Calculé pour une sensibilité nominale de 1,6 pC/N

Stiftdurchmesser broche de diamètre pin diameter [mm]	Empfindlichkeit sensibilité sensitivity [pC/bar]	Stiftdurchmesser broche de diamètre pin diameter [mm]	Empfindlichkeit sensibilité sensitivity [pC/bar]
1,6	-0,32	6	-4,52
2	-0,5	8	-8,04
2,5	-0,78	10	-12,56
3	-1,13	12	-18,09
4	-2,01	14	-24,62
5	-3,14		

Application

Although the mold cavity pressure in industrial applications is normally measured directly in the cavity, there are situations in which this is not possible, for example for reasons of space.

PinSens is a cost-effective alternative in such cases.

Scope of delivery

	Art.No.
Mounting plate	3.520.328
Cheese-head screw	6.120.166
Spring washer	6.230.049

Accessories

Type	
High-temperature extension cable sheathed in steel braiding Fischer SE102A014-TNC pos.	
Length 2 m	1672A2
Length 5 m	1672A5
High-temperature extension cable, Teflon Fischer SE102A014-BNC pos	
Length 2 m	1667A2
Length 5 m	1667A5
Clamp for connector	1401

Conversion table

Calculated with nominal sensitivity of 1,6 pC/N

Abbildungen / Figure / Figure

- Einbau mit befestigtem Kraftsensor / Montage avec capteur de force fixé / Mounting with fixed force sensor
- Abmessungen der Einbaunut / Dimension de la rainure de montage / Dimensions of mounting groove
- Montageplatte / Plaque de montage / Mounting plate

000-128m-02.02 (DB06.92048m)

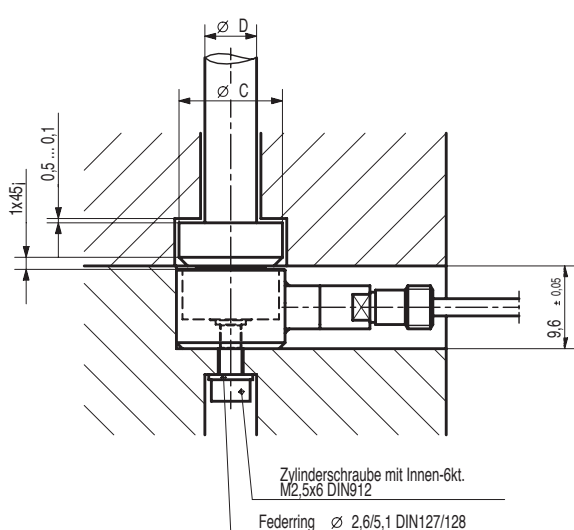

Fig. 1

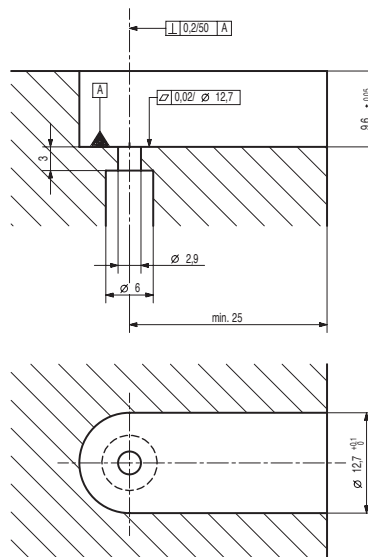

Fig. 2

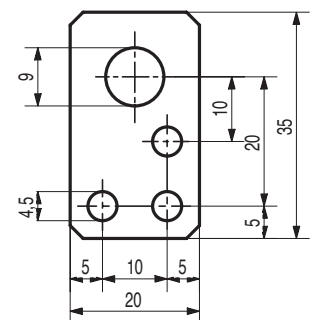

Fig. 3