

آزما صنعت گراد



نماینده انحصاری کمپانی **Mahr** آلمان

|
- 0 +



EXACTLY

MARSURF | MARSURF XR 1 - MARWIN



PC-BASED MOBILE SURFACE MEASURING STATIONS

|
- 0 +



EXACTLY

COMPACT - CONVENIENT - COST-EFFICIENT MOBILE WITH MARSURF



For the most current information on
MARSURF products, please visit:
www.mahr.de, Webcode 14322



► | The mobile surface measuring units from Mahr already brought Bluetooth technology into the world of metrology. Mahr continually developed this technology further. The result is the new MarSurf XR 1.

The MarSurf XR 1 unites mobile surface metrology with the benefits of a MarWin evaluation software. That means, for a roughness or waviness measurement, a simple all-in-one computer and the suitable drive unit suffice - but laptops and industrial PCs can also be used. The Bluetooth technology offers an extra degree of freedom: In addition to the cable connection between the feed unit and evaluation unit, the connection also works wirelessly. The measurement can be triggered easily via the touch screen or the appropriate feeder. Flexible solutions, easy software connections and the most diverse possibilities - all offered by the surface metrology from Mahr.

▶ | MarSurf XR 1

MarSurf. PC-based mobile surface measuring units	4
MarSurf XR 1. General description	5
MarSurf XR 1 Measuring station with RD 18	6
MarSurf XR 1 Measuring station with SD 26	7
MarSurf XR 1. Set-up, software and options	8
MarSurf XR 1. Application examples software	11
MarSurf XR 1. Application examples	12
MarSurf XR 1. Data transfer to PC	14
MarSurf XR 1. Accessory sets	16
MarSurf XR 1. Probe arm overview for SD 26	17
MarSurf XR 1. Probe arm overview for RD 18	22
MarSurf XR 1. Measuring station accessories	24
MarSurf XR 1. Technical data	25
MarSurf XR 1. Advantages	26

MarSurf. PC-based mobile surface measuring stations VERSATILE AND POWERFUL IN PRODUCTION, MEASURING ROOM AND LAB

▶ | The surface measuring unit MarSurf XR 1 is the inexpensive and convenient entry into comfortable and future-oriented surface metrology. According to the measurement task, the measuring station can be configured with skidded or skidless tracing. Mahr offers the instrument in combination with the drive units MarSurf RD18 and MarSurf SD26, providing for two measuring station variants for simple roughness measurements - with simultaneous software connection with the most diverse possibilities. Equipment and software together fulfill all the requirements of a modern PC-operated measurement and evaluation. International standards, diverse evaluation methods, extensive documentation, large storage capacity, data export and import as well as networking with other systems are today's essential demands on a PC-based system. | ◀

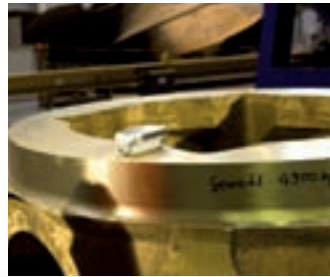
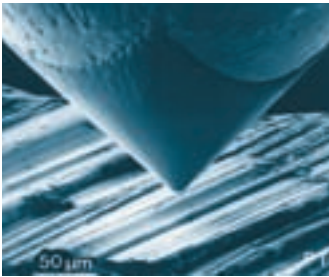

MarSurf XR 1

Easy measurement of roughness and waviness



Description

With **MarSurf XR 1** you can enter into the top class of surface metrology from Mahr. Whether in the measuring room or in production, the PC-based unit provides all common parameters and profiles of international standards.

Several drive units can be connected to the evaluation unit via Bluetooth or cable.

Clear, well-arranged symbols and convenient user aids simplify the handling of this powerful product. Decades of experience in surface metrology and modern, cutting-edge technology are united in the **MarSurf XR 1**.

MarSurf XR 1 at **Mahr** means future-oriented roughness software.

Features

- The roughness measurement software has the following features:
- Over 80 parameters for R, P, W profile according to current standards, ISO/JIS or MOTIF (ISO 12085) selectable
 - Band pass filter L_s according to current standards, L_s can also be switched off or freely varied
 - Extensive measuring records
 - Quick and Easy measuring programs can be quickly created in a user-guided function
 - Automatic function for the selection of cutoff and measuring path according to standards (patented)
 - Different calibration methods are supported (static and dynamic) with specification of parameters R_a or R_z
 - Maintenance and calibration intervals are selectable
 - Many measuring station configurations are possible for each individual application case
 - System flexibility due to different options
 - Different user levels protect from erroneous use of the unit and ensure that unauthorized users cannot operate the unit

The evaluation software described here can be expanded as desired. The options available are described on the following pages.

MarSurf XR 1 with Drive Unit MarSurf RD 18 and ST-G

Measuring station for roughness measuring with the drive unit MarSurf XR 1 and skidded probe PHT6-350



Description

Measuring station for roughness measurements with drive unit MarSurf RD 18 and skidded probe PHT6-350. This measuring station is characterized by easy and uncomplicated handling. All parameters based on roughness depth are available. The characteristics of the evaluation software **MarSurf XR 1** in the basic version are described on pages 8 and 12.

Measuring station components

MarSurf XR 1 Set

- Software and license
- Adapter for drive units
- USB cable

Order no. 6268390



MarSurf RD 18 Set

- Drive unit MarSurf RD 18
- Probe PHT6-350

Order no. 6910416



All-In-One PC

May optionally be provided by customer according to Mahr specification

Order no. 9054848

Support MarSurf RD 18 on ST-G

Order no. 6910201

Cross table CT 120

Order no. 6710529

Measuring stand ST-G

Order no. 6710807

- Granite plate 500 mm x 300 mm (L x W) with centered 10 mm T-groove
- Measuring column with manual height adjustment range of 300 mm for the drive unit

Drive unit MarSurf RD 18

- Tracing direction lengthwise
- Settable tracing length MarSurf XR 1 as per DIN/ISO: 1.75 mm, 5.6 mm, 17.5 mm as per EN ISO 12085: 1 mm, 2 mm, 4 mm, 8 mm, 12 mm, 16 mm
- Tracing speed: 0.5 mm/s
- Dimensions \varnothing 24 mm, L = 112 mm

Skidded probe PHT 6-350

System	Single-skid probe
Skid radius	in tracing direction 25 mm, transverse 2.9 mm
Floating point	0.8 mm in front of the probe tip
Measuring range	350 μ m
Specification	for flat surfaces, bores
	from 6 mm \varnothing to 17 mm depth, grooves
	from 3 mm width
	min. workpiece length = tracing length + 1 mm

MarSurf XR 1 with Drive Unit SD 26 and ST-G

Roughness and waviness measurements on small and medium-sized workpieces



Description

Measuring station for the measurement of roughness depths, P profile and waviness with the drive unit MarSurf SD 26 and the skidless tracing system BFW 250.

Special features of this measuring station include:

- Automatic zero positioning
- Fast probe arm change without tools

The characteristics of the evaluation software **MarSurf XR 1** in the basic version are describe on pages 8 and 12.

Measuring station components

MarSurf XR 1 Set

- Software and license
- Adapter for drive units
- USB cable

Order no. 6268390



MarSurf SD 26 Set

- Drive unit MarSurf SD 26
- Probe BFW-250

Order no. 6910415



All-In-One PC

May optionally be provided by customer according to Mahr specification

Order no.. 9054848

Mount MarSurf SD 26 to ST-G

Order no. 6910436

Cross table CT 120

Order no. 6710529

Measuring stand ST-G

Order no. 6710807

- Granite plate 500 mm x 300 mm (L x W) with centered 10 mm T-groove
- Measuring column with manual height adjustment range of 300 mm for the drive unit

Drive unit MarSurf SD 26 incl. probe system

- The drive unit **MarSurf SD 26** with built-in reference level for precise measurement up to 25.4 mm (1 inch)
- Rz residual values < 30 nm when tracing speed 0.1 mm/s
- Can be used horizontally, vertically and upside down
- Motorized height adjustment of the drive unit with automatic zero setting
- Measuring path 26 mm
- Measuring speed 0.2 mm/s; 1 mm/s
- Positioning speed in X 5 mm/s
- Height adjustment Z 7.5 mm, motorized
- Positioning speed in Z 2 mm/s
- **Skidless probe system BFW Set**
Measuring range $\pm 250 \mu\text{m}$ (with double probe arm length $\pm 500 \mu\text{m}$)
Low probe force of approx. 0.7 mN
High probe linearity < 1 %
Fast probe arm change due to magnetic probe arm holder

MarSurf XR 1. Software and Options

Basic version MarSurf XR 1

Basic version Software MarSurf XR 1 Order no. 6268390

- Measuring station view
- Automatic user registration
- R-profile and parameters
- Rk-profile and parameters
- P-profile and parameters
- W-profile and parameters
- Motif profile and parameters
- D-profile and parameters
- Export ASCII
- Profile assistant for USB devices
- Measuring assistant Level I (simple setting of measuring conditions)
- MT Surf for RD 18 and SD 26

Software option "Advanced Evaluation"

Option "Advanced Evaluation"

Order no. 6292272

- Automatic export of profile data
- Result files and records in PDF format
- Interactive zoom to specify a profile range that is to be evaluated and the re-calculation of the selected parameters
- Virtual rule for interactive specification of distances in X and Z direction in the profile field and depiction in the record

Software option "Multi Measure"

Option "Multi Measure"

Order no. 6292273

- Expansion of the measuring assistant with the function of Levels 2 and 3
- Statistics
- User administration to register and manager users with different rights

Software option "Protocol"

Option „Advanced Protocol“

Order no. 6292274

- PageDesigner to create user-specific protocol templates (forms)
- Tolerance monitoring and records with tolerance display

Software option "Integration of Script Programs"

Option "Integration of Script Programs"

Order no. 6292277

This option enables the following functions:

- Starting MarScript program from F-keys
- The measuring assistant enables the execution of MarScript programs
- QE RUN function

MarSurf XR 1. Additional Software Options

Option "Digital I/O"

Option "Digital I/O" Order no. 6268392

- For all MarWin software
- Digital I/O box with 8 inputs / 8 outputs
- License "Digital I/O" and short manual
- Remote control e.g. by a PLC for the integration of the MarWin measuring station into a manufacturing process
- Execution of measurements

Option "QS-STAT"

Option "QS-STAT" Order no. 6292268

- Simple export of features acc. to Q-DAS
- Support of 31 AutoKeys

Option "QS-STAT Plus"

Option "QS-Stat Plus" Order no. 6292271

- Simple export of features acc. to Q-DAS
- Manual
- Possibility to change e.g. type, length, description
- Possibility to integrate customer requirements and measuring programs

Option "Dominant Waviness"

Option "Dominant Waviness" Order no. 6292203

- Acc. to VDA 2007: 2007-02
- Calculable WD parameters:
WDSm, WDC and WDt

Option "Profile Processing"

Option "Profile Processing" Order no. 6292269

- The option is divided into 3 areas of operation:
 - a) Edge filter
With this roughness measurement function, areas can be hidden that should not be included in the analysis.
 - b) Profile editing
With this function, profiles can be edited, such as grooves or tips cut out, ball simulations, mirroring of profiles, turning profiles, inserting additional areas etc.
 - c) Placing profiles together
With this function, profiles from two or more profiles can be put together to form one new profile.

Option "User-Defined Parameters"

Option "User-Defined Parameters" Order no. 6292270

- With this option, a new parameter group can be created in the products MarSurf XR 1, MarSurf XR 20 or MarSurf XCR 20.

The corresponding parameters can be programmed and integrated by the customer with the support of the Mahr Application Department.

Option "ISO 13535-3 Parameters"

Option "ISO 13535-3 Parameters" Order no. 6292263

- With this option, the special parameters Rpq, Rmq and Rvq can be evaluated as per ISO 13565-3.

MarSurf XR 1. Further Options

Option RD 18 C



Option Set "MarSurf RD 18 C"

Order no. 6910417

- Cylindrical drive unit MarSurf RD 18 C
- Skidded probe PHT 6-350 / 2 μm
- Hand-held vee
- Support to mount MarSurf RD 18 C to a holding devices (clamping shaft \varnothing 8 mm)
- Height adjustment
- Probe protection
- Probe protection with prismatic base
- Connecting cable RD 18 C (for drive interface - RD 18 C)

Option RD 18 C2

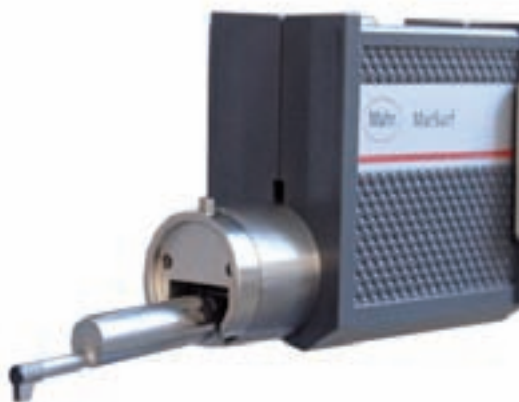

Option Set "MarSurf RD 18 C2"

Order no. 6910418

- Cylindrical drive unit MarSurf RD 18 C2 for measurements in traverse direction
- Skidded probe PHT 6-350 / 2 μm
- Hand-held vee
- Support to mount MarSurf RD 18 C to a holding devices (clamping shaft \varnothing 8 mm)
- Height adjustment
- Probe protection
- Probe protection with prismatic base
- Connecting cable RD 18 C (for drive interface - RD 18 C)

Option Drive Interface RD 18 C



Option Set "Drive Interface RD 18 C"

Order no. 6268391

- Drive interface RD 18 C to connect drive unit MarSurf RD 18 C / RD 18 C2 to a computer with the software MarSurf XR 1 or to a MarSurf M 300
- Connecting cable drive interface RD 18 C – Computer
- Operating instructions

MarSurf XR 1. Application Examples

Application: Knee joint



Measurement of a knee joint
with drive unit MarSurf RD 18 and skided probe system PHTR-100



Application: Stepped shaft



Measurement of a stepped shaft
with drive units MarSurf SD 26
and MarSurf RD 18
• Connection of several drive units possible



Application: Ship propeller



Measurement of a ship propeller
with the drive unit MarSurf RD 18
and the probe system PHT 6-350,
without cable



MarSurf XR 1 Software

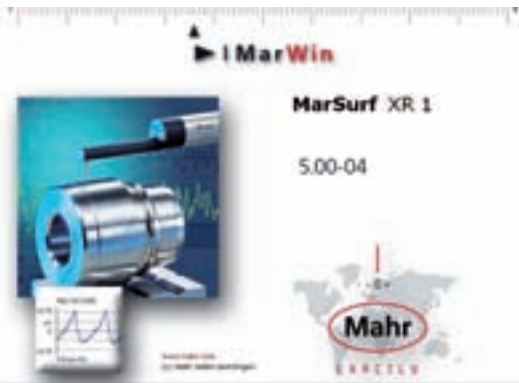

The software platform MarWin enables the user to use a service that is characterized by easy operability for varied measuring and evaluation criteria.



Simple representation of the measuring station with the axes belonging to the measuring set up to allow quick and safe working.

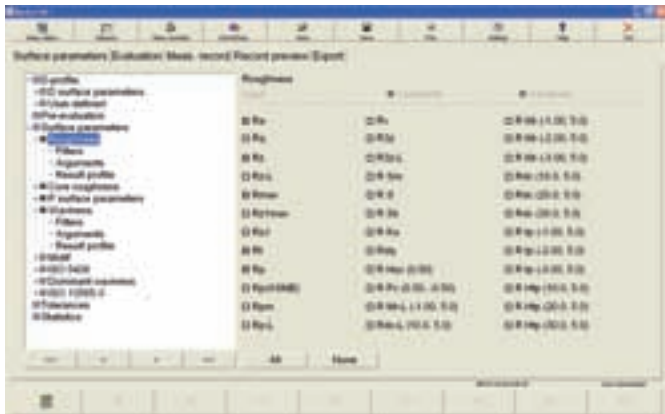

Results, profiles, standardized parameters and characteristics curves can be activated by a "click" and output into the test record. The corresponding entries can be directly selected use the tabs: Properties, analysis, protocol, protocol preview and offer the user a quick and easy operator control.

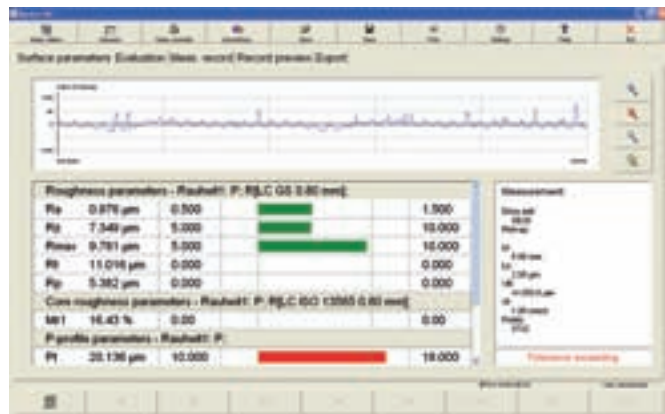

Here in the "evaluation" view example, the result with the profile, ADK curve and tolerance control is integrated into the software option "Protocol".

MarSurf XR 1 Software

With the measuring assistant, all measuring conditions can be specifically set for the measuring task. In the option "Multi Measure", operator prompts assist you in entering e.g. positioning prior to as well as after the measurements.

In the view "Probe System" the drive units as well as the probe arms are specified once. The probe arms can be individually named for easy allocation.

The "Meas. Record" tab enables you to enter profile information into the protocol head.

Excerpt from the option: "Advanced Evaluation". Virtual rule for the interactive specification of distances in X and Z direction in the profile field enable the defined measuring ranges to be observed.

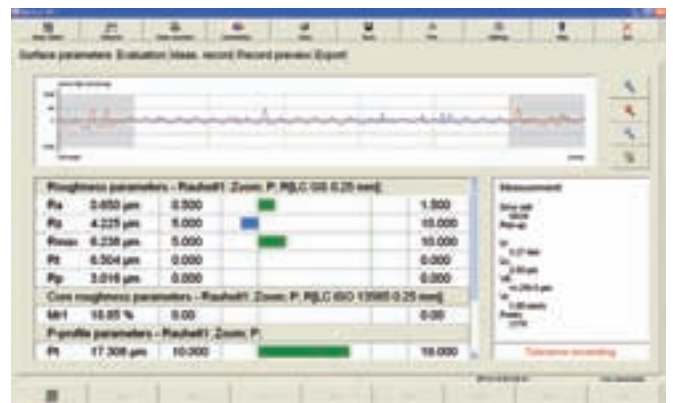
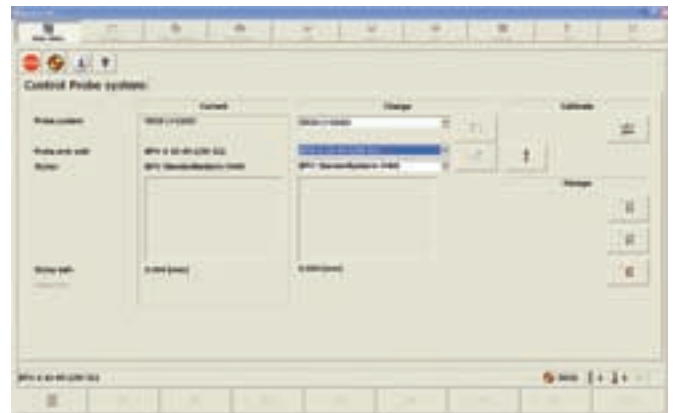
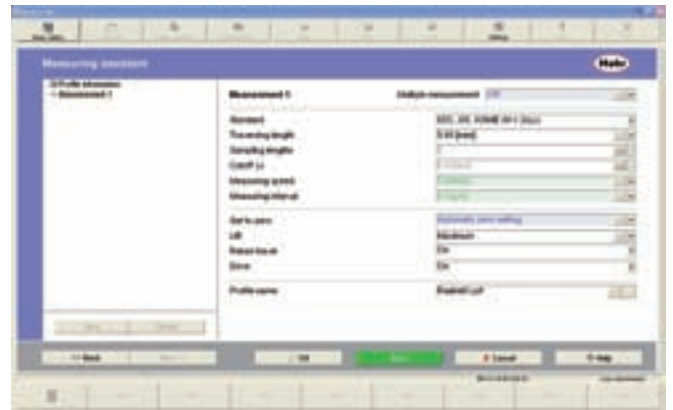

MarSurf XR 1. Data Transfer from Drive Unit to PC

- Connection of any number of drive units using drive unit adapter
- **Alternatively:**
Drive units MarSurf RD 18 and MarSurf SD 26 can be connected to the PC via the Bluetooth interface. Connectivity must only be established once. The drive units stored in the measuring programs immediately begin when the measurement is activated!

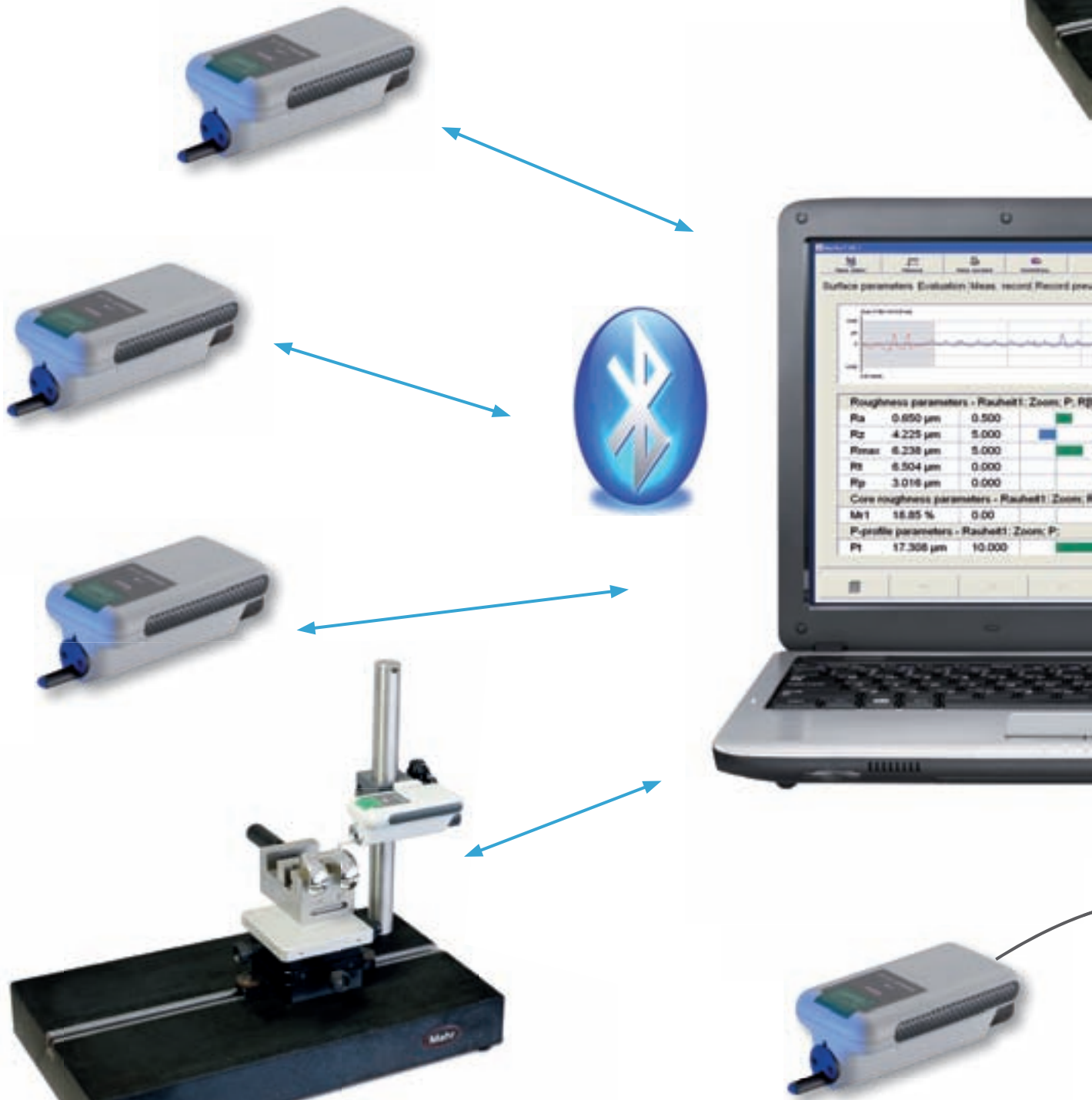

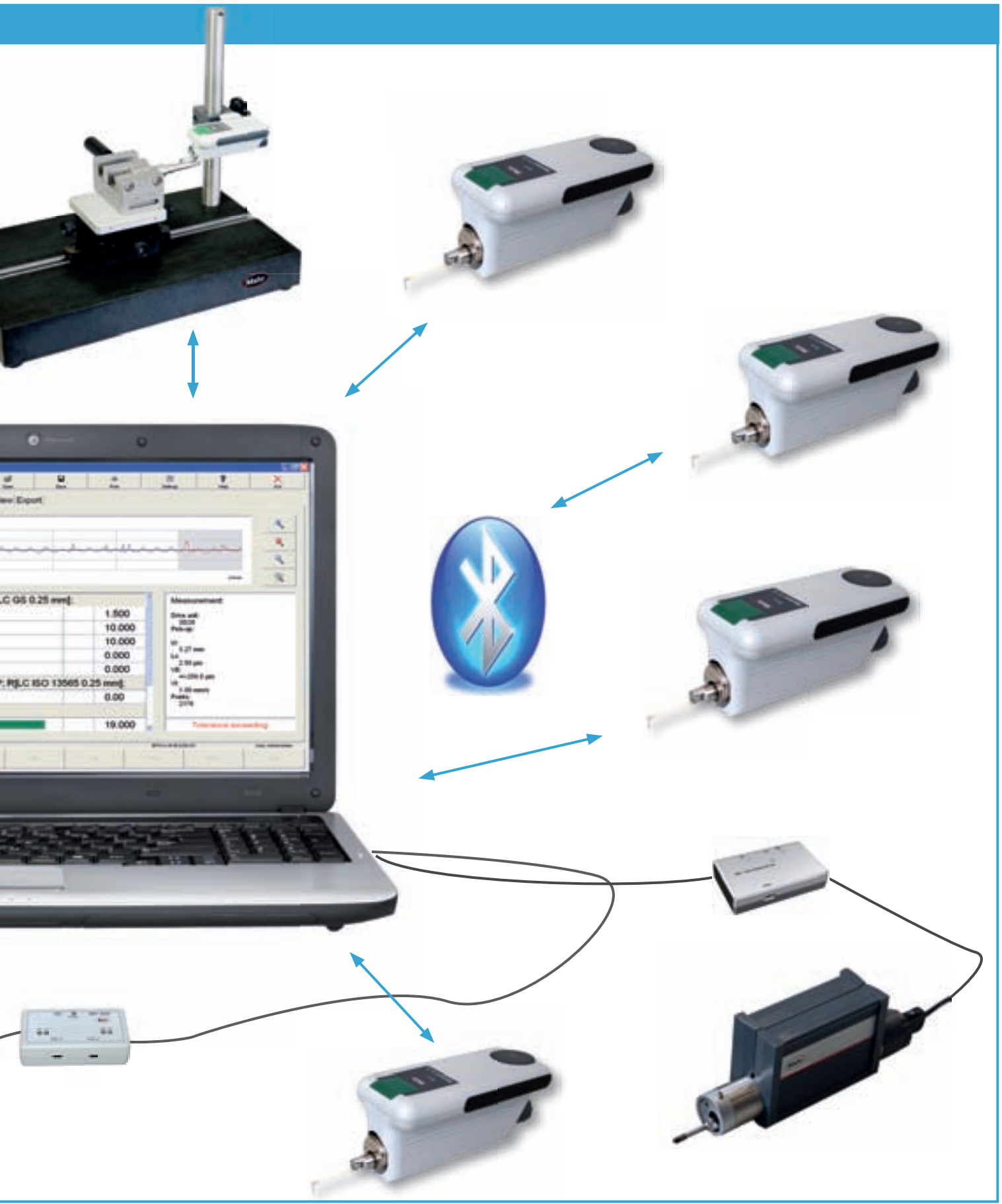

MarSurf XR 1. Accessories

MarSurf SD 26 Set



Set "MarSurf SD 26"

Order no. 6910415

consisting of:

- Drive unit MarSurf SD 26 with reference plane
- Skidless probe system BFW-250 with probe arm BFW A 10-45-2/90°
- Mains adapter
- Connecting cable SD 26 for drive interface
- Operating instructions

MarSurf RD 18 Set



Set "MarSurf RD 18"

Order no. 6910416

consisting of:

- Drive unit MarSurf RD 18
- Skidded probe PHT 6-350 / 2 μm
- Integrated standard
- Height adjustment
- Probe protection
- Probe protection with prismatic base
- End face vee-block
- Mains adapter
- Connecting cable SD 26 for drive interface
- Operating instructions

Accessories



• Drive unit adapter

Order no. 7047701

For the connection of drive unit to MarSurf RD 18 and MarSurf SD 26 to a computer

• USB cable

Order no. 8165044

Drive unit adapter to PC

MarSurf XR 1. Overview of Probe Arms for Drive Unit MarSurf SD 26

Probe head BFW-250 integrated in MarSurf SD 26

Skidless probe system BFW-250

Probe head firmly integrated in drive unit SD 26

Measuring range $\pm 250 \mu\text{m}$ (for 45 mm probe arm length)
 $\pm 500 \mu\text{m}$ (for 90 mm probe arm length)

Low probe force of approx. 0.7 mN
 High probe linearity $< 1\%$

Magnetic probe arm support for easy exchange of probe arms also provides additional probe arm protection.



BFW probe arm A 10-45-2/90°

Probe arm BFW A 10-45-2/90°
for bores from $\varnothing 11 \text{ mm}$ on
 (probe included in standard set)

Order no. 6852403

Probe tip radius / material $2 \mu\text{m}$ / diamond
 Opening angle of probe tip 90°
 Measuring range $\pm 250 \mu\text{m}$

Length A (length below probe arm) 8.0 mm
 Length B (length up to center of support) 36.5 mm

For use with bores from 11 mm on approx. 30 mm

Same probe arm with $5 \mu\text{m}$ 90° diamond = 6852419
 Same probe arm with $2 \mu\text{m}$ 60° diamond = 6852418

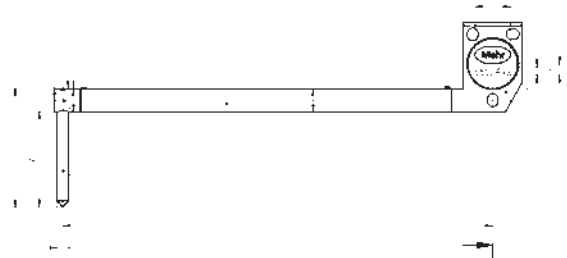

BFW probe arm A 0.7-45-2/90°

Probe arm BFW A 0.7-45-2/90°
for bores from 0.9 mm on

Order no. 6852408

Probe tip radius / material $2 \mu\text{m}$ / diamond
 Opening angle of probe tip 90°
 Measuring range $\pm 250 \mu\text{m}$

Length below the probe arm 0.1 mm
 Length up to center of support 36.5 mm

For use with Bores from $\varnothing 0.9 \text{ mm}$ on approx. 10 mm
 Bores from $\varnothing 2.5 \text{ mm}$ on approx. 30 mm

Same probe arm with $5 \mu\text{m}$ 90° diamond = if required via Order Construction Dept. (9xxx)

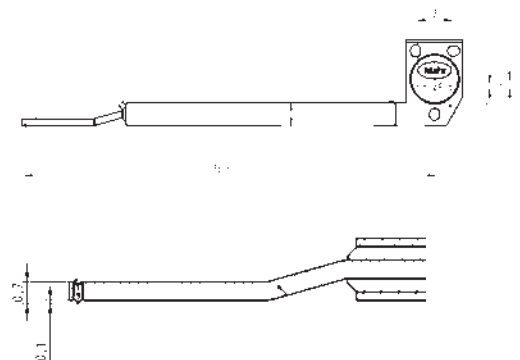

MarSurf XR 1. Overview of Probe Arms for Drive Unit SD 26

BFW probe arm A 1.4-45-2/90°

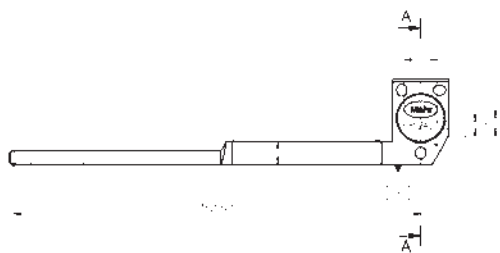

Probe arm BFW A 1.4-45-2/90° for bores from \varnothing 1.5 mm on

Order no. 6852407

Probe tip radius / material 2 μ m / diamond
Opening angle of probe tip 90°
Measuring range \pm 250 μ m

Length A (length below probe arm) 0.2 mm
Length B (length up to center of support) 36.5 mm

For use with
bores from \varnothing 1.5 mm on approx. 30.0 mm

Same probe arm with 5 μ m 90° diamond = via Order Construction Dept. if required (9xxx)

BFW probe arm A 4-45-2/90°

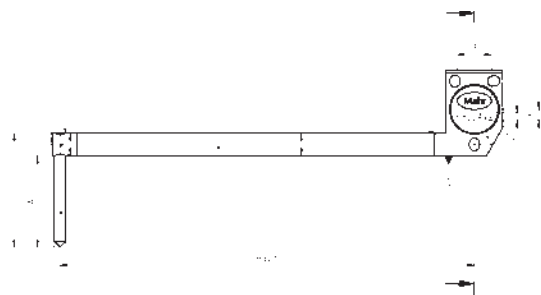

Probe arm BFW A 4-45-2/90° for bores from \varnothing 4.5 mm on

Order no. 6852404

Probe tip radius / material 2 μ m / diamond
Opening angle of probe tip 90°
Measuring range \pm 250 μ m

Length A (length below probe arm) 2 mm
Length B (length up to center of support) 36.5 mm

For use with
bores from \varnothing 4.5 mm on approx. 30 mm

Same probe arm with 5 μ m 90° diamond = via Order Construction Dept. if required (9xxx)

BFW probe arm A 22-45-2/90°

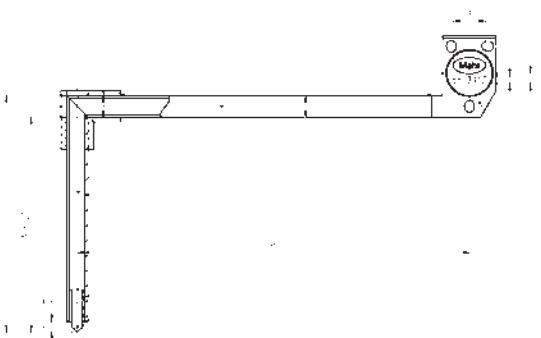

Probe arm BFW A 22-45-2/90° for recesses up to approx. 20 mm

Order no. 6852412

Probe tip radius / material 2 μ m / diamond
Opening angle of probe tip 90°
Measuring range \pm 250 μ m

Length A (length below probe arm) 20 mm
Length B (length up to center of support) 36.5 mm

For use with
bores from \varnothing 23 mm on approx. 30 mm

MarSurf XR 1. Overview of Probe Arms for Drive Unit MarSurf SD 26

BFW probe arm A 32-45-2/90°

**Probe arm BFW A 32-45-2/90°
for recesses up to approx. 30 mm**

Order no. 6852413

Probe tip radius / material 2 μm / diamond
Opening angle of probe tip 90°
Measuring range $\pm 250 \mu\text{m}$

Length A (length below probe arm) 30 mm
Length B (length up to center of support) 36.5 mm

For use with
bores from $\varnothing 33 \text{ mm}$ on approx. 30 mm

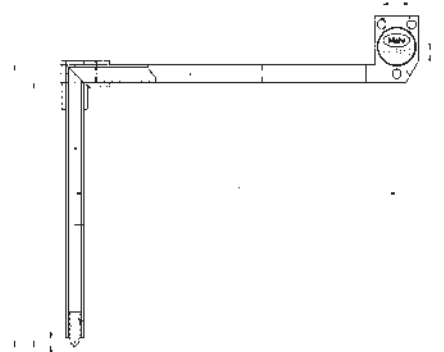

BFW probe arm A 42-67.5-2/90°

**Probe arm BFW A 42-67.5-2/90°
for recesses up to approx. 40 mm**

Order no. 9049160

Probe tip radius / material 2 μm / diamond
Opening angle of probe tip 90°
Measuring range $\pm 375 \mu\text{m}$

Length A (length below probe arm) 40 mm
Length B (length up to center of support) 59 mm

For use with
bores from $\varnothing 43 \text{ mm}$ on approx. 55 mm

Note: Crank may not be longer than the probe arm, therefore 50% longer probe arm required for this crank.

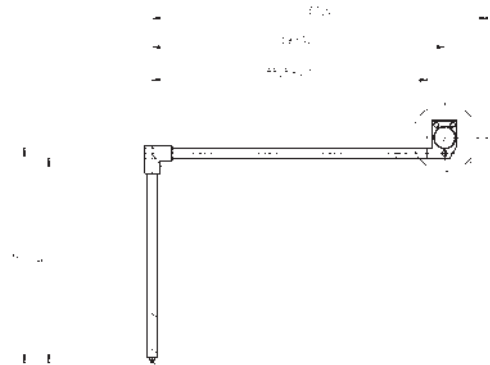

BFW probe arm A 52-67.5-2/90°

**Probe arm BFW A 52-67.5-2/90°
for recesses up to approx. 50 mm**

Order no. 9049161

Probe tip radius / material 2 μm / diamond
Opening angle of probe tip 90°
Measuring range $\pm 375 \mu\text{m}$

Length A (length below probe arm) 50 mm
Length B (length up to center of support) 59 mm

For use with
bores from $\varnothing 53 \text{ mm}$ on approx. 55 mm

Note: Crank may not be longer than the probe arm, therefore 50% longer probe arm required for this crank.

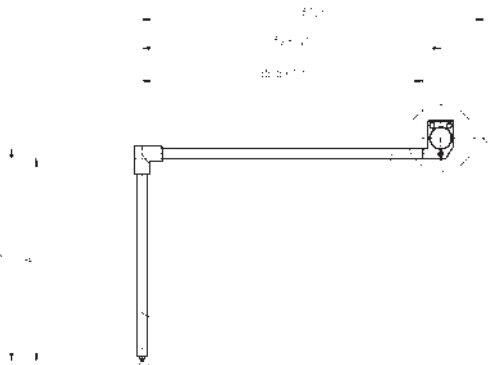

MarSurf. Overview of Probe Arms for Drive Unit MarSurf SD 26

BFW probe arm A 2.8-45-2/90°-q6.5

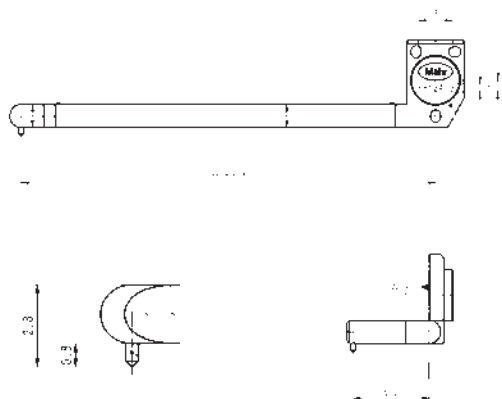

Probe arm BFW A 2.8-45-2/90°-q6.5 angled laterally

Order no. 6852409

Probe tip radius / material
Opening angle of probe tip
Measuring range

2 μm / diamond
60°
 $\pm 250 \mu\text{m}$

Length below the probe arm
(Length up to center of support)
Lateral crank

0.8 mm
36.5 mm
6.5 mm

Bores from $\varnothing 3.5 \text{ mm}$ on

approx. 6.0 mm
(lateral measurement)

Bores from $\varnothing 12 \text{ mm}$ on

approx. 30.0 mm
(axial measurement)

BFW probe arm A 2.8-45-2/60°

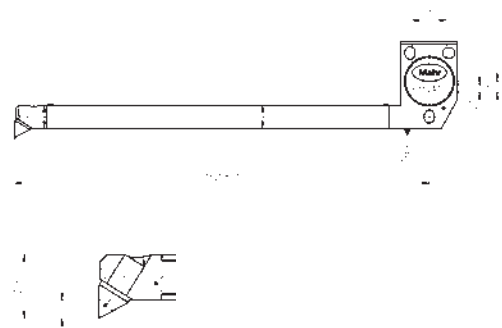

Probe arm BFW A 2.8-45-2/60°-s32° with slanted tip

Order no. 6852410

Probe tip radius / material
Opening angle of probe tip
Measuring range

2 μm / diamond
60°
 $\pm 250 \mu\text{m}$

Length below the probe arm
(Length up to center of support)

0.8 mm
36.5 mm

Diamond angle

32°

Bores from $\varnothing 3.5 \text{ mm}$ on

approx. 30.0 mm

BFW probe arm A 42-90-2/90°

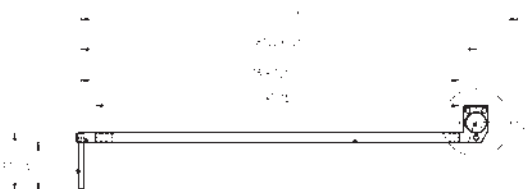

Probe arm BFW A 12-90-2/90° for measuring range $\pm 500 \mu\text{m}$, for bores from $\varnothing 13 \text{ mm}$ on

Order no. 9048672

Probe tip radius / material
Opening angle of probe tip
Measuring range

2 μm / diamond
90°
 $\pm 250 \mu\text{m}$

Length A (length below probe arm)
Length B (length up to center of support)

10 mm
81.5 mm

For use with
Bores from $\varnothing 13 \text{ mm}$ on

ca. 75.0 mm

Same probe arm with 5 μm 90° diamond = via Order
Construction Dept. if required (9xxx)

MarSurf. Overview of Probe Arms for Drive Unit MarSurf SD 26

BFW probe arm A 10-135-2/90°

Probe arm BFW A 10-135-2/90° for measuring range $\pm 750 \mu\text{m}$, for bores from $\varnothing 11 \text{ mm}$ on **Order no. 6852411**

Probe tip radius / material	2 μm / diamond
Opening angle of probe tip	90°
Measuring range	$\pm 750 \mu\text{m}$
Length A (length below probe arm)	8 mm
Length B (length up to center of support)	126.5 mm

For use with
bores from $\varnothing 11 \text{ mm}$ on approx. 123 mm

Same probe arm with 5 μm 90° diamond = via Order Construction Dept. if required (9xxx)

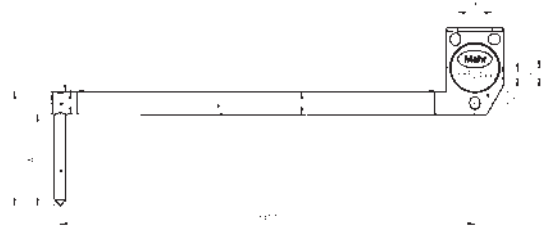

BFW probe arm A 4-90-2/90°

Probe arm BFW A 4-90-2/90° for measuring range $\pm 500 \mu\text{m}$, for bores from $\varnothing 4.5 \text{ mm}$ on **Order no. 6852406**

Probe tip radius / material	2 μm / diamond
Opening angle of probe tip	90°
Measuring range	$\pm 500 \mu\text{m}$
Length A (length below probe arm)	2.0 mm
Length B (length up to center of support)	81.5 mm

For use with
bores from $\varnothing 4.6 \text{ mm}$ on approx. 75 mm

Same probe arm with 5 μm 90° diamond = via Order Construction Dept. if required (9xxx)

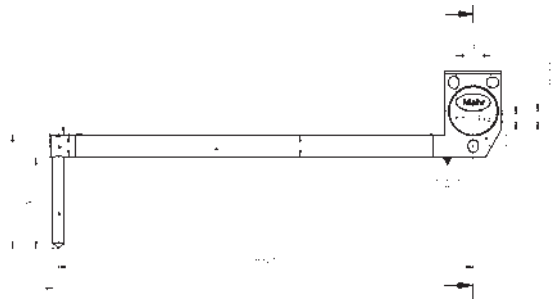

BFW probe arm A 42-90-2/90°

Probe arm BFW A 42-90-2/90° for recesses up to approx. 40 mm **Order no. 9048671**

Probe tip radius / material	2 μm / diamond
Opening angle of probe tip	90°
Measuring range	$\pm 500 \mu\text{m}$
Length A (length below probe arm)	40 mm
Length B (length up to center of support)	81.5 mm

For use with bores from $\varnothing 43 \text{ mm}$ on approx. 78 mm

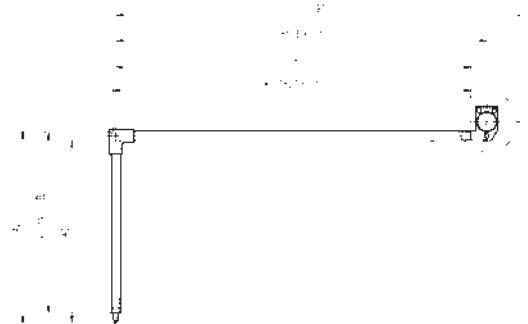

BFW-250

Skid for BFW probe **Order no. 6852402**

Only for standard probe, item no. 6852403	
Total length	46.4 mm

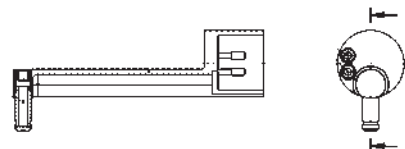

MarSurf XR 1. Overview of Probe Arms for Drive Unit MarSurf SRD 18 / RD 18 C / RD 18 C2

Probe for a variety of measuring tasks using RD 18

The P probes are characterized by specific design features:

- Probe tip geometry acc. to EN ISO 3274, standard $2\ \mu\text{m}/90^\circ$
- Standardized measuring force of approx. $0.7\ \text{mN}$ (acc. to EN ISO 3274)
- Reliable inductive converter
- Sturdy, rigid housing
- Self-adjusting, spring loaded bearings
- Reliable plug connection



Probe PHT 6-350

Order no. 6111520 (standard probe)

System
Skid radius
Contact point
Measuring range
Specification

Single-skidded probe
in tracing direction 25 mm, across 2.9 mm
0.8 mm in front of the probe tip
 $350\ \mu\text{m}$
for smooth surfaces, bores from 6 mm \varnothing up to 17 mm deep,
grooves from 3 mm width,
min. workpiece length = tracing length + 1 mm

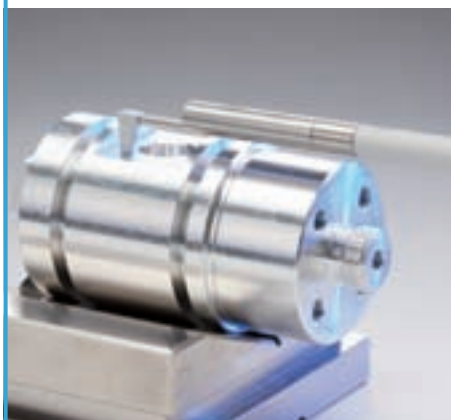
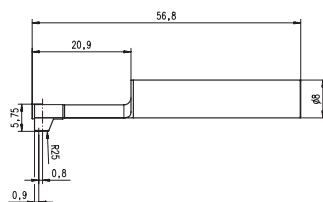

Probe PHT 11-100

Order no. 6111524

System
Skid radius
Contact point
Measuring range
Specification

Single-skidded probe
in tracing direction 25 mm, across 2.9 mm
0.8 mm in front of the probe tip
 $100\ \mu\text{m}$
for smooth surfaces, bores from 11 mm \varnothing up to 4 mm deep
grooves from 2.5 mm wide and up to
7.5 mm deep

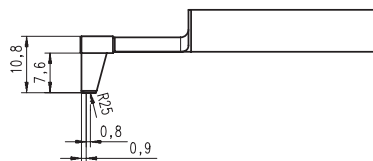

Probe PT 150

Order no. 6111523

System
Skid radius
Contact point
Measuring range
Specification

Double-skidded probe
in tracing direction 50 mm, across 3 mm
4.5 mm in front of the probe tip
 $150\ \mu\text{m}$
for sheet metal and cylindrical surfaces
acc. to DIN EN 10049 (SEP)
with workpiece length = tracing length + 5 mm

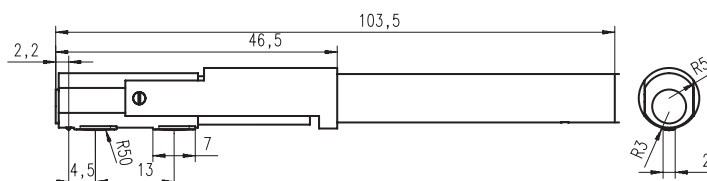

MarSurf XR 1. Overview of Probe Arms for Drive Unit MarSurf RD 18 / RD 18 C / RD 18 C2

Probe PHT 3-350

Order no. 6111521

System Single-skidded probe
 Skid radius in tracing direction 25 mm, across 1.45 mm
 Contact point 0.9 mm in front of the probe tip
 Measuring range 350 μm
 Specification for bores from 3 mm \varnothing on, up to 17 mm deep,
 min. workpiece length = tracing length + 1 mm

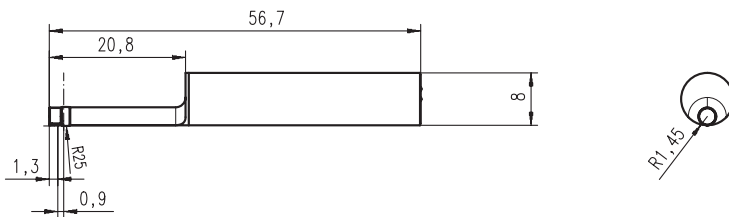

Probe extension PHT (80 mm), Order no. 6850540 (for P-probes)

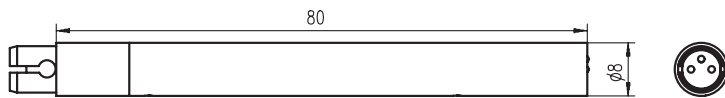

Probe PHTF 0.5-100

Order no. 6111522

can be calibrated with PGN 3

System Single-skidded probe
 Skid radius in tracing direction 25 mm, across 1.45 mm
 Contact point 0.6 mm next to the probe tip
 Measuring range 100 μm
 Specification e.g. for tooth surfaces from module 0.8 on

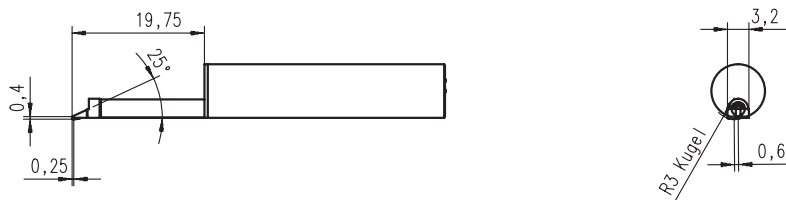

Probe PHTR-100

Order no. 6111525

can be calibrated with PGN 3

System Single-skidded probe with lateral skid
 Skid radius 0.3 mm in tracing direction
 Probe tip 2 μm , 90°
 Specification for measurements on concave and convex surfaces

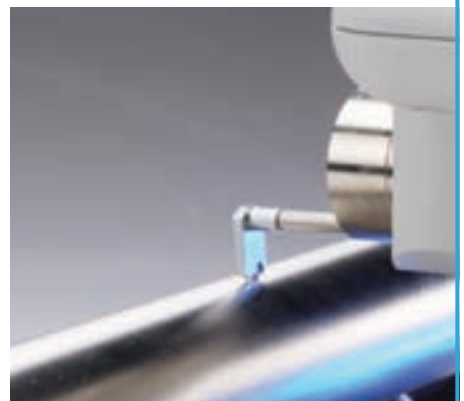
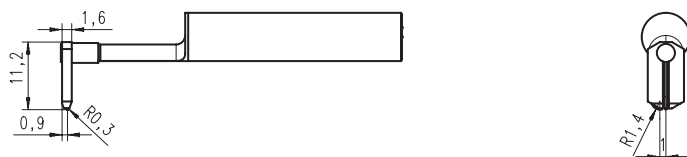

MarSurf XR 1. Measuring Station Accessories

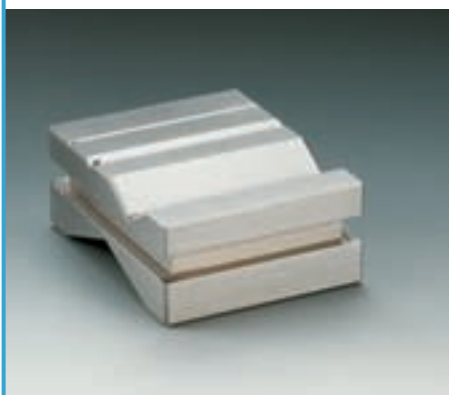

Vee-block PP

Order no. 6710401

With four different prisms to support rotational parts for test diameters of 1 mm to 160 mm.

Dimensions: 80 mm x 100 mm x 40 mm

Weight: 1.5 kg

Incl. tensions springs for holding light-weight measuring objects in prism.



Parallel vice PPS

Order no. 6710604

To clamp measuring objects

- Jaw width: 70 mm
- Jaw height: 25 mm
- Clamping width: 40 mm
- Total height: 58 mm
- Weight: 2 kg



XY-Tisch CT 120

Order no 6710529

To mount and align measuring objects.

Can be moved 15 mm in each of two coordinates.

Table surface: 120 mm x 120 mm,
with two quick clamping
jaws

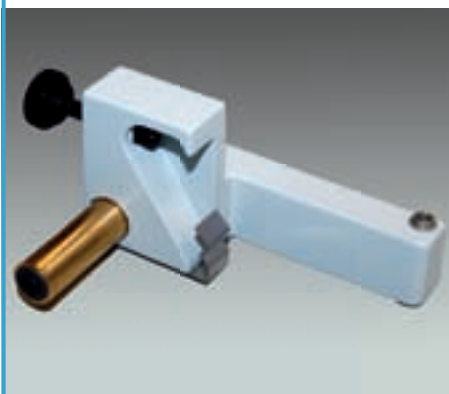

Mount for MarSurf RD 18

Order no. 6910201

The drive unit can be arreted and swiveled by pivoting the mount ($\pm 15^\circ$)

Mount for MarSurf SD 26

Order no. 6910436



Geometry standard PGN 3

Order no. 6820601

Surface standard with sinusoidal groove profile.

Profil depth approx. 3 μm , Ra value approx. 1 μm ,

Profile distance approx. 0.12 mm.

For dynamic testing of the roughness measuring station.

Mahr calibration certificate for PGN 3

Order no. 9027715

DKD/DAkkS calibration certificate for

PGN 3

Order no. 6980102



Roughness standard PRN 10

Order no. 6820420

Including Mahr calibration certificate.

Surface standard with turned profile, metal, profile depth approx. 10 μm , for testing of the roughness measuring station.

MarSurf XR 1. Technical Data

Measuring principle	Tactile stylus method	Drive unit speeds (Vt)	SD 26: 0.1 mm/s und 0.5 mm/s 1.0 mm/s RD 18: 0.5 mm/s
Probes	Skidless tracing BFW 250 Skidded tracing - PHT series	Parameters	
Drive units	Skidless tracing - SD 26 Skidded tracing - RD 18, RD 18 C, RD 18 C2	Roughness parameters (RD 18/SD 26):	Ra, Rq, Rz (Ry acc. to JIS corresponds to Rz), Rmax, R _{Pc} , Rz(JIS), Rt, Rp, Rq (ASME), R _{pm} , Rv, R3z, RSm, RS (corresponds to S acc. to JIS), Rsk, Rku, Rdq, Rlq, Rdc, R HSC, RMr*, RMr*, RMr*, Rz1max
Measuring ranges	SD 26 - see page 7 RD 18 - see page 6	Core roughness parameters (RD 18/SD 26):	Rk, Rpk, Rvk, Rpkx, Rv _{kx} , Mr1, Mr2, A1, A2, Vo, R _{Pm} , Rtp, R _{Htp}
Profile resolution / resolution for SD 26		Parameters P profile (only SD 26):	Pa, Pq, Pt, Pp, Pv, PSm, Psk, Pku, Pdq, Plq, Pdc, P HSC, P _{Pc} , PMr*, PMr*, PMr*, R _z (JIS 1982), PTIR-1, PTIR-2
vertical	±25 µm / 0.7 nm ±250 µm / 7 nm ±2500 µm / 50 nm approx. 100.000 increments per measuring range	Parameters W profile (only SD 26):	Wa, Wq, Wt, Wp, Wv, WSm, Wsk, Wku, Wdq, Wdc, WMr*, WMr*, WMr*, WTIR-1, WTIR-2, Wst
horizontal	Point distance acc. to DIN EN ISO 3274 (11.200 points for 5.6 mm measuring path; user defined max. 52.000 points possible)	Parameters motif (ISO 12085) (only SD 26):	R, AR, W, AW, Rx, Wx, Wte, Nr, Ncrx, Nw, Cpm, CR, CF, CL
Profile resolution / resolution for RD 18	8 nm	ISO-5436 parameters (only SD 26):	Pt5436, D
Profile types	SD 26: D-, P-, W-, R-, Rk-, WD-profile, (profile inversion possible) RD 18: R-profile, Rk-profile	List of parameters:	Rz-L, Rp-L, R3z-L, Rdc-L, RMr-L Pdc-L, PMr-L, P-step-L
Filter types	Gaussian filter DIN EN ISO 11562 Gaussian filter ISO 16610-21 Robust Gaussian filter ISO 16610-31 Spline filter ISO 16610-22 RC filter DIN 4768: 1974 Rk filter DIN EN ISO 13565-1 Robust spline filter ISO 16610-32 Re filter ISO 12085	Automatic function	automatic selection of standardized cutoff acc. to DIN EN ISO 3274
Form elimination	SD 26: ARC filter	Languages	German, English, French, further languages upon request
Cutoff length	SD 26: 0.08 mm; 0.25 mm; 0.8 mm; 2.5 mm; 8 mm/free input RD 18: 0.25 mm; 0.8 mm; 2.5 mm; free input	Software	released for WINDOWS® 7 and WIN XP SP3
Tracing paths	SD 26: automatic; 0.56 mm; 1.75 mm; 5.6 mm; 17.5 mm, 26 mm, measure to stop, variable RD 18: automatic; 1.75 mm; 5.6 mm; 17.5 mm	Subject to technical changes.	
Number of individual measuring paths	1 to 50 (standard: 5)		
Special tracing paths	0.1 mm up to traverse length, adjustable (0.008 in to 12 in)		
Low pass Ls	2.5 µm / 8 µm / 25 µm acc. to DIN EN ISO 3274, can be switched off and freely varied		

* Material ratio calculated with CREF reference or mean line

MarSurf XR 1. Your Advantages



Your advantages at a glance

Compact

- Few components
- Touchscreen operation
- MarWin software in combination with mobile drive units
- High-performance basic software

Convenient

- Self-installation by customer
- Plug and Play
- Software expandable with software packets
- Several drive units can be connected via cable or Bluetooth
- AQDEF certification for "Mobile Unit"
- Digital I/O for remote control operation

Cost-effent

- Low entry price

WWW.MAHR.COM

- 0 +

Mahr

E X A C T L Y



Azma Sanat Grad

آزما صنعت گراد

تست و اندازه گیری . تجهیزات . مشاوره

Unit 3 - 2ndfloor- No.24 West Shahid Ghandi St.
North Sohrevardi Ave. Tehran . Iran
Tel : +98 21 88745209 , 86030765
Fax: +98 21 88764890

تهران - خیابان سهروردی شمالی - خیابان شهید قندی غربی
پلاک ۲۴ - ورودی غربی - طبقه دوم - واحد ۳
تلفن : ۸۶۰۳۰۷۶۵ ، ۸۸۷۴۵۲۰۹
فاکس : ۸۸۷۶۴۸۹۰

www.asgradco.com info@asgradco.com