



آزما صنعت گراد



نماینده انحصاری کمپانی **Mahr** آلمان



EXACTLY

YOUR MEASURING TASKS ARE SENSITIVE. **MARTEST IS HIGHLY SENSITIVE.**



The latest information on MARTEST products can be found on our website:

www.mahr.com, WebCode 10407

► | Since 1936 Mahr is one of the leading global producers of test indicators, we have achieved this with the continuous advancement of our products and with unrelenting commitment to produce high quality products that not only meet customer requirements but also exceed them. We have also increased research and development in order to satisfy the demands and requirements of the market, however our core philosophy is to offer our customer a highly accurate and simple solution for various measuring tasks. With the MarTest series of test indicators there is not just a broad product range but also a wide variety of accessories at your disposal. The sensitive computer-optimized shockproof mechanism of the test indicator ensures maximum security and precision. MarTest is ideal for use in workshop conditions due to the dial being sealed thus impervious to the penetration of liquids. | ◀

▶ | MarTest. Test Indicators and Touch Probes

Mechanical Dial Test Indicators

Overview

4- 2

Standard version

MarTest 800 S / 800 SG / 800 SA / 800 SGA

metric

4- 4

MarTest 801 S1 / 801 S / 801 SG / 801 SGI

inch

4- 4

With a higher resolution

MarTest 800 SM / 800 SGM / 800 SGE

metric

4- 5

MarTest 801 SM / 801 SGM / 801 SGE

inch

4- 5

With a longer styli

MarTest 800 SL / 800 SGL / 800 SGB

metric

4- 6

MarTest 801 SL / 801 SGL

inch

4- 6

Horizontal version

MarTest 800 H

metric

4- 7

MarTest 801 H

inch

4- 7

Vertical version

MarTest 800 V / 800 VGM

metric

4- 7

MarTest 801 V / 801 VGM

inch

4- 7

With a larger measuring range

MarTest 800 SR / 800 SRM

metric

4- 8

MarTest 801 SR / 801 SRM

inch

4- 8

Digital Test Indicators

Standard version

MarTest 800 EW

4- 9

With a longer styli

MarTest 800 EWL

4-10

Accessories

4 - 8 / 4-11

3D-Touch Probes

Water proof, with a Digital display

MarTest 802 NW

4-14







Water proof, with an Analog display

MarTest 802 EW

4-15

MarTest. Test Indicators

OVERVIEW

MarTest - Versions		Measuring range	Dial style	Readings	DIN 2270	Accuracy														
						f_{ges}	f_e	f_u	f_t	f_w										
	Standard	metric																		
		800 S	± 0.4 mm	0-40-0	0.01 mm	●	13 µm	10 µm	3 µm	5 µm	3 µm									
		800 SG	± 0.4 mm	0-40-0	0.01 mm	●	13 µm	10 µm	3 µm	5 µm	3 µm									
		800 SA	± 0.25 mm	0-25-0	0.01 mm		8 µm	5 µm	3 µm	5 µm	3 µm									
		800 SGA	± 0.25 mm	0-25-0	0.01 mm		8 µm	5 µm	3 µm	5 µm	3 µm									
		800 EW	± 0.4 mm ± .015"	digital	0.001/ .0005" 0.01/ .0005"	●		10 µm	3 µm											
		inch																		
		801 S1	± .015"	0-15-0	.001"		.0005"	.0004"	.00012"	.0002"	.0002"									
		801 S	± .015"	0-15-0	.0005"		.0005"	.0004"	.00012"	.0002"	.0002"									
		801 SG	± .015"	0-15-0	.0005"		.0005"	.0004"	.00012"	.0002"	.0002"									
	801 SGI	± .015" (± 0.30 mm)	0-15-0 (0-30-0)	.001" (0.01 mm)		.0005"	.0004"	.00012"	.0002"	.0002"										
	Extra Long Styli	metric																		
		800 SL	± 0.25 mm	0-25-0	0.01 mm		13 µm	10 µm	5 µm	5 µm	3 µm									
		800 SGL	± 0.25 mm	0-25-0	0.01 mm		13 µm	10 µm	5 µm	5 µm	3 µm									
		800 SGB	± 0.5 mm	0-50-0	0.01 mm		13 µm	10 µm	4 µm	5 µm	3 µm									
		800 EWL	± 0.25 mm ± .010"	digital	0.001/ .00005" 0.01/ .0005"			10 µm	3 µm											
		inch																		
		801 SL	± .010"	0-10-0	.0005"		.0005"	.0004"	.0002"	.0002"	.00012"									
		801 SGL	± .010"	0-10-0	.0005"		.0005"	.0004"	.0002"	.0002"	.00012"									
		Higher Resolution	metric																	
			800 SM	± 0.1 mm	0-100-0	0.002 mm	●	4 µm	3 µm	2 µm	2 µm	1.5 µm								
		800 SGM	± 0.1 mm	0-100-0	0.002 mm	●	4 µm	3 µm	2 µm	2 µm	1.5 µm									
		800 SGE	± 0.07 mm	0-70-0	0.001 mm		4 µm	3 µm	2 µm	2 µm	1.5 µm									
		inch																		
		801 SM	± .004"	0-4-0	.0001"		.00016"	.00012"	.00008"	.00008"	.00006"									
		801 SGM	± .004"	0-4-0	.0001"		.00016"	.00012"	.00008"	.00008"	.00006"									
		801 SGE	± .004"	0-4-0	.00005"		.00016"	.00012"	.00008"	.00008"	.00006"									
		Larger Measuring Range	metric																	
			800 SR	± 0.8 mm	0-40-0	0.01 mm		14 µm	10 µm	4 µm	5 µm	3 µm								
		800 SRM	± 0.2 mm	0-100-0	0.002 mm		5 µm	3 µm	3 µm	2 µm	1.5 µm									
		inch																		
		801 SR	± .030"	0-15-0	.0005"		.0005"	.0004"	.00016"	.0002"	.00012"									
		801 SRM	± .008"	0-4-0	.0001"		.0002"	.00012"	.00012"	.00008"	.00006"									
	Horizontal Models	metric																		
		800 H	± 0.4 mm	0-40-0	0.01mm	●	13 µm	10 µm	3 µm	5 µm	3 µm									
		inch																		
	801 H	± .015"	0-15-0	.0005"		.0005"	.0004"	.00012"	.0002"	.00012"										
	Vertical Models	metric																		
		800 V	± 0.4 mm	0-40-0	0.01 mm	●	13 µm	10 µm	3 µm	5 µm	3 µm									
		800 VGM	± 0.1 mm	0-100-0	0.002 mm	●	4 µm	3 µm	2 µm	2 µm	1.5 µm									
		inch																		
		801 V	± .015"	0-15-0	.0005"		.0005"	.0004"	.00012"	.0002"	.00012"									
	801 VGM	± .004"	0-4-0	.0001"		.00016"	.00012"	.00008"	.00008"	.00006"										

* Only available in North America, Canada and Mexico; includes holding bar and clamp

Length of styli	Order no.	Order no. with kit*
14.5 mm	4305200	2015309
14.5 mm	4307200	2015310
14.5 mm	4301200	2015343
14.5 mm	4301250	2015344
14.5 mm	4305120	
14.5 mm	4305960	2015317
14.5 mm	4305950	2015316
14.5 mm	4307950	2015318
14.5 mm	4307970	2015311

41.24 mm	4306200	2015312
41.24 mm	4306250	2015313
32.3 mm	4301300	2015346
41.24 mm	4306120	

41.24 mm	4306950	2015319
41.24 mm	4306960	2015320

14.5 mm	4308150	2015315
14.5 mm	4308200	2015314
9.1 mm	4308220	2015345

14.5 mm	4308960	2015321
14.5 mm	4308970	2015322
14.5 mm	4308985	2015323

14.5 mm	4307250	2015348
14.5 mm	4308250	2015349

14.5 mm	4307960	2015350
14.5 mm	4308980	2015351

14.5 mm	4303200	2015328
---------	---------	---------

14.5 mm	4303950	2015324
---------	---------	---------

14.5 mm	4302200	2015327
14.5 mm	4302250	2015347

14.5 mm	4302950	2015325
14.5 mm	4302960	2015326

Metrological characteristics

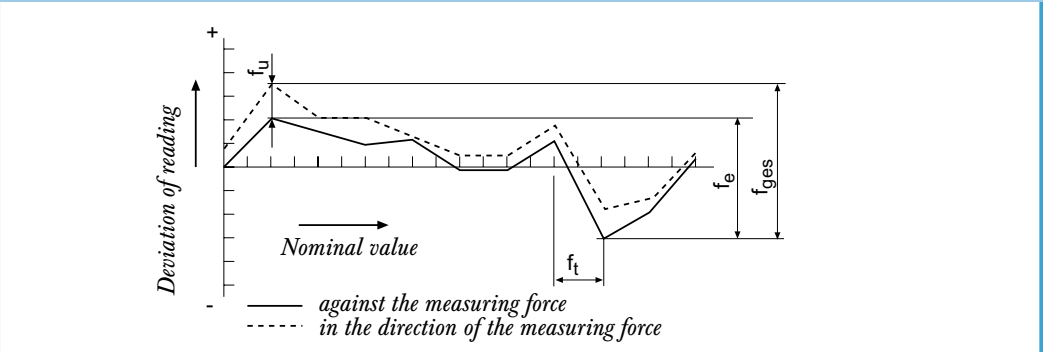

MarTest - Design features

SHOCK PROOF

- Dial face is sealed with an O-Ring
- Satin chrome finished housing
- Contact point with carbide ball
- Double lever supported in ball bearings, overload protection provided by slip clutch

Mechanism

- Shockproof
- Anti magnetic
- Movement bearings are jeweled with 8 precious stones
- Automatic matching to sensing direction, thus ensuring error-free reading

MarTest - Applications

Concentricity of a shaft

Concentricity of a sleeve

Centering of a bore

Aligning a surface

Testing parallelism

MarTest standard versions

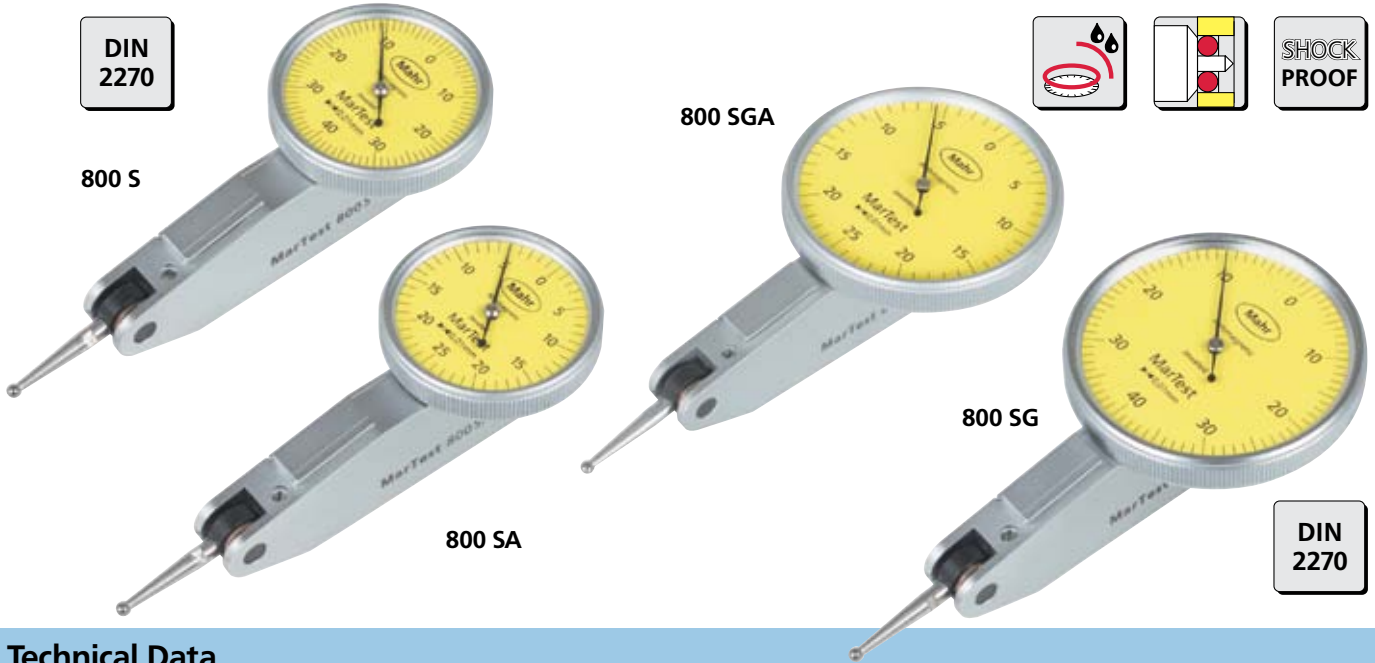

Technical Data

	Measuring range	Readings	Dial dia.	Measuring force	Length of styli	Order no.	Order no. with kit
800 S	± 0.4 mm	0.01 mm	27.5 mm	0.15 N	14.5 mm	4305200	2015309
800 SG	± 0.4 mm	0.01 mm	38 mm	0.15 N	14.5 mm	4307200	2015310
800 SA	± 0.25 mm	0.01 mm	27.5 mm	0.1 N	14.5 mm	4301200	2015343
800 SGA	± 0.25 mm	0.01 mm	38 mm	0.1 N	14.5 mm	4301250	2015344
801 S1	± .015"	.001"	1.1"	0.15 N	14.5 mm	4305960	2015317
801 S	± .015"	.0005"	1.1"	0.15 N	14.5 mm	4305950	2015316
801 SG	± .015"	.0005"	1.5"	0.15 N	14.5 mm	4307950	2015318
801 SGI	± .015" (± 0.3 mm)	.0005" (0.01 mm)	1.5"	0.15 N	14.5 mm	4307970	2015311

Supplied with:

Plastic storage case, spanner for changing the styli, styli dia. 2 mm, mounting shaft 800 a8 (for metric versions), mounting shaft 800 a6 (800 SA, 800 SGA), mounting shaft 800 a3/8 (for inch versions)

801 S1

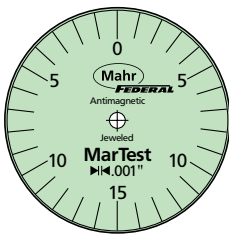

801 S

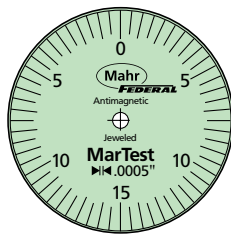

801 SG

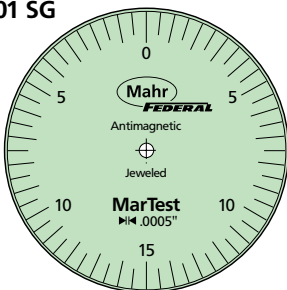

801 SGI

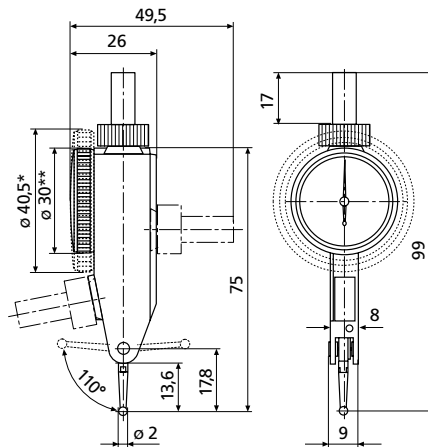
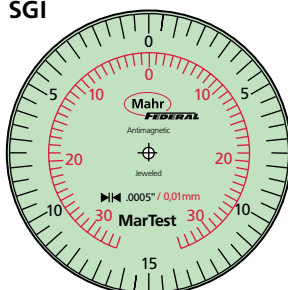

* 800 SG, 800 SGA, 801 SG, 801 SGI

** 800 S, 800 SA, 801 S1, 801 S

MarTest with resolution 0.002 mm/0.001 mm for higher accuracy

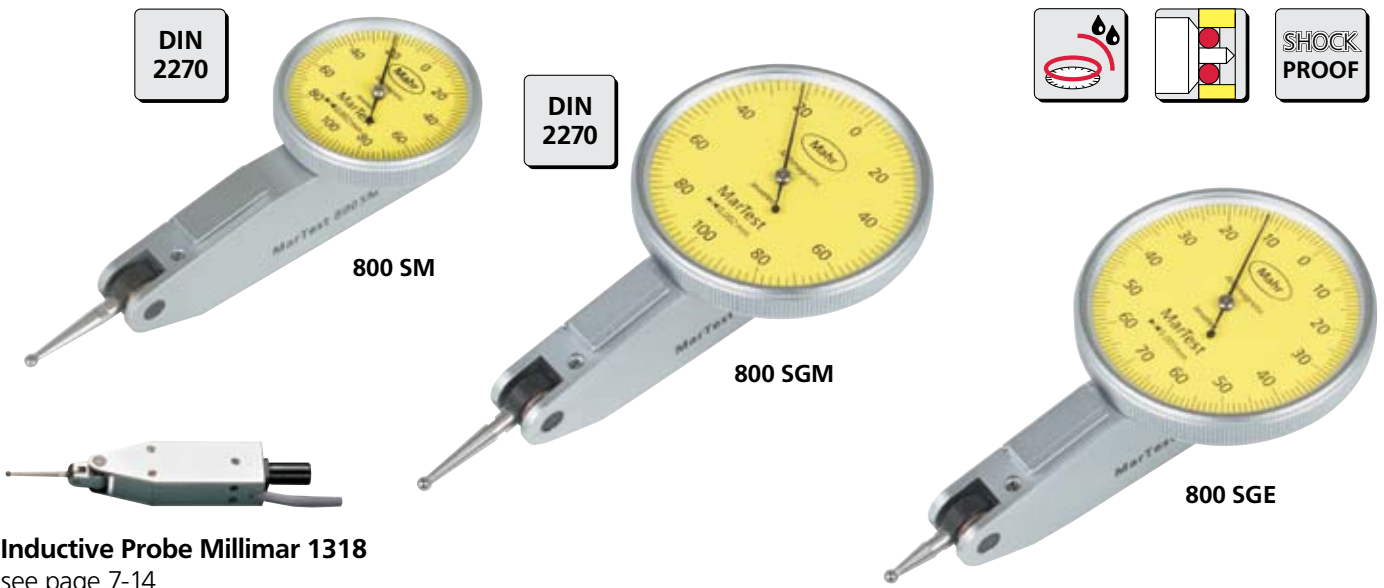

Inductive Probe Millimar 1318
see page 7-14

Technical Data

	Measuring range	Readings	Dial dia.	Measuring force	Length of styli	Order no.	Order no. with kit
800 SM	± 0.1 mm	0.002 mm	27.5 mm	0.15 N	14.5 mm	4308150	2015315
800 SGM	± 0.1 mm	0.002 mm	38 mm	0.15 N	14.5 mm	4308200	2015314
800 SGE	± 0.07 mm	0.001 mm	38 mm	0.2 N	9.1 mm	4308220	2015345
801 SM	± .004"	.0001"	1.1"	0.15 N	14.5 mm	4308960	2015321
801 SGM	± .004"	.0001"	1.5"	0.15 N	14.5 mm	4308970	2015322
801 SGE	± .004"	.00005"	1.5"	0.15 N	14.5 mm	4308985	2015323

Supplied with:
Plastic storage case, spanner for changing the styli, styli dia. 2 mm, mounting shaft 800 a8 (for metric versions)

801 SM

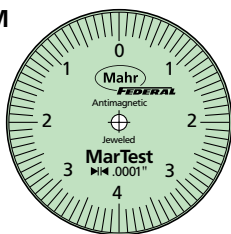

801 SGM

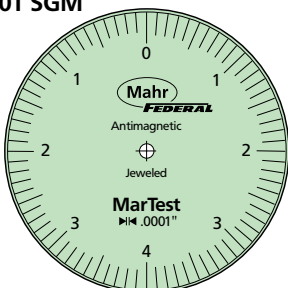

801 SGE

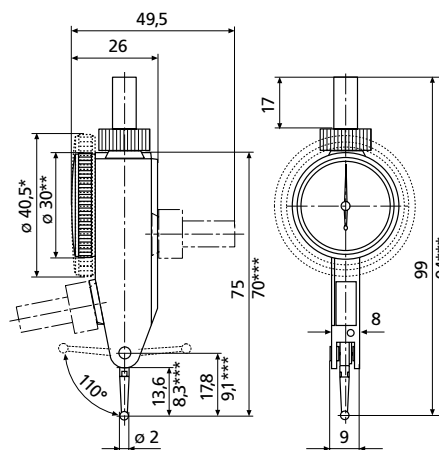
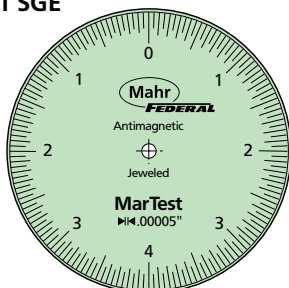

* 800 SGM, 800 SGE, 801 SGM, 801 SGE
** 800 SM, 801 SM
*** 800 SGE

MarTest with extra long styli for measuring in even difficult to access positions



Technical Data

	Measuring range	Readings	Dial dia.	Measuring force	Length of styli	Order no.	Order no. with kit
800 SL	± 0.25 mm	0.01 mm	27.5 mm	0.07 N	41.24 mm	4306200	2015312
800 SGL	± 0.25 mm	0.01 mm	38 mm	0.07 N	41.24 mm	4306250	2015313
800 SGB	± 0.5 mm	0.01 mm	38 mm	0.1 N	32.3 mm	4301300	2015346
801 SL	± .010"	.0005"	1.1"	0.07 N	41.24 mm	4306950	2015319
801 SGL	± .010"	.0005"	1.5"	0.07 N	41.24 mm	4306960	2015320

Supplied with:

Plastic storage case, spanner for changing the styli, styli dia. 2 mm, mounting shaft 800 a8 (for metric versions), mounting shaft 800 a3/8 (for inch versions), mounting shaft 800 a6 (800 SGB)

801 SL

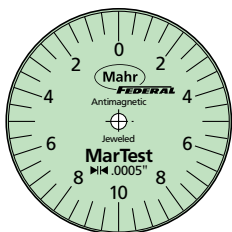

801 SGL

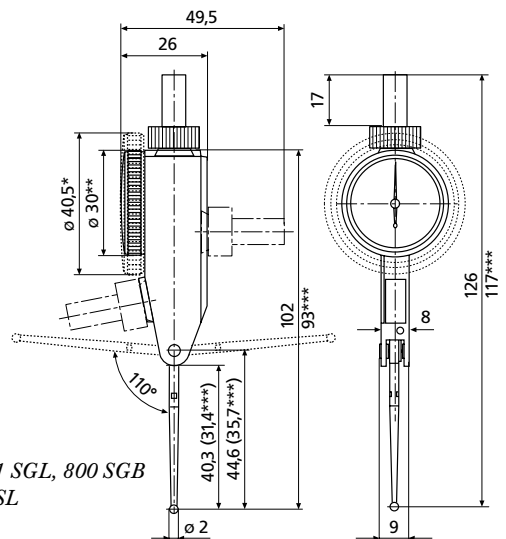
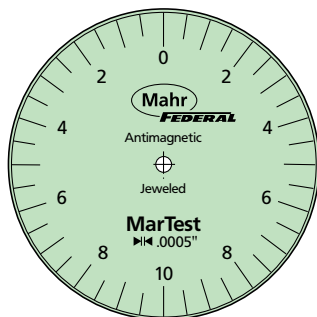

* 800 SGL, 801 SGL, 800 SGB
 ** 800 SL, 801 SL
 *** 800 SGB

MarTest styli can positioned horizontally to the dial face

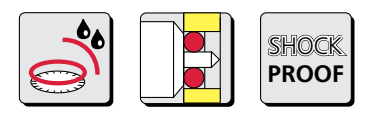
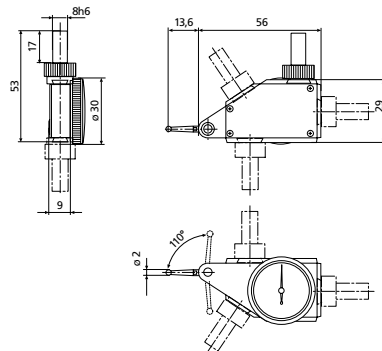

800 H

Technical Data

	Measuring range	Readings	Dial dia.	Measuring force	Length of styli	Order no.	Order no. with kit
800 H	± 0.4 mm	0.01 mm	27.5 mm	0.25 N	14.5 mm	4303200	2015328
801 H	± .015"	.0005"	1.1"	0.25 N	14.5 mm	4303950	2015324

Supplied with:
 Plastic storage case, spanner for changing the styli, styli dia. 2 mm, mounting shaft 800 a8 (for metric versions), mounting shaft 800 a3/8 (for inch versions)

MarTest vertical model

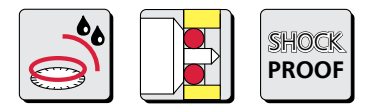
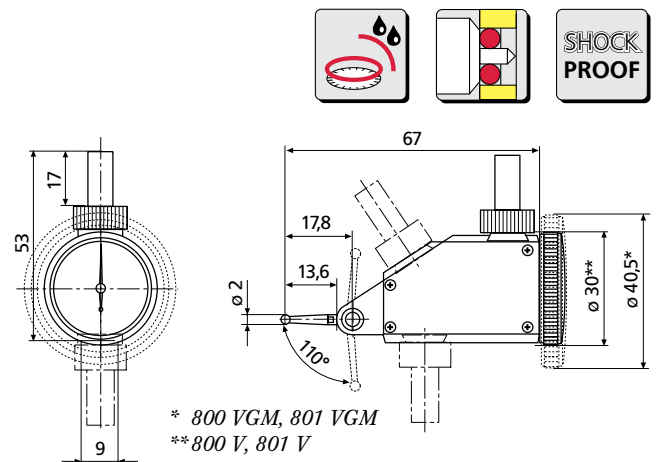
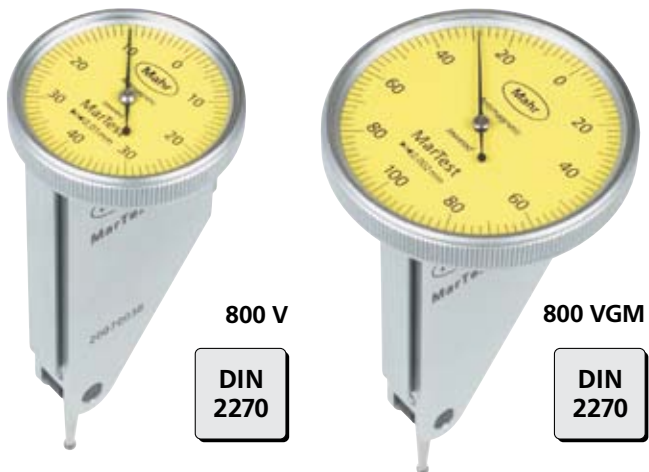

Technical Data

	Measuring range	Readings	Dial dia.	Measuring force	Length of styli	Order no.	Order no. with kit
800 V	± 0.4 mm	0.01 mm	27.5 mm	0.2 N	14.5 mm	4302200	2015327
800 VGM	± 0.1 mm	0.002 mm	38 mm	0.25 N	14.5 mm	4302250	2015347
801 V	± .015"	.0005"	1.1"	0.2 N	14.5 mm	4302950	2015325
801 VGM	± .004"	.0001"	1.5"	0.25 N	14.5 mm	4302960	2015326

Supplied with:
 Plastic storage case, spanner for changing the styli, styli dia. 2 mm, mounting shaft 800 a8 (for metric versions), mounting shaft 800 a3/8 (for inch versions)

MarTest with larger measuring range



800 SRM

800 SR/SRM

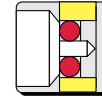
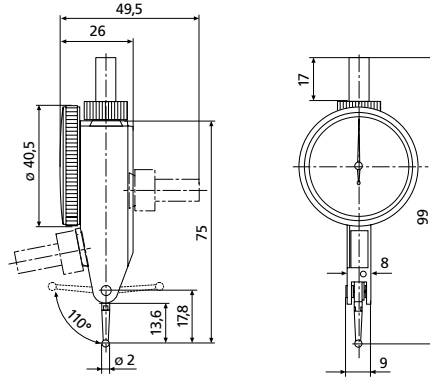

Technical Data

	Measuring range	Readings	Dial dia.	Measuring force	Length of styli	Order no.	Order no. with kit
800 SR	± 0.8 mm	0.01 mm	38 mm	0.15 N	14.5 mm	4307250	2015348
800 SRM	± 0.2 mm	0.002 mm	38 mm	0.15 N	14.5 mm	4308250	2015349
801 SR	± .030"	.0005"	1.5"	0.15 N	14.5 mm	4307960	2015350
801 SRM	± .008"	.0001"	1.5"	0.15 N	14.5 mm	4308980	2015351

Supplied with:
 Plastic storage case, spanner for changing the styli, styli dia. 2 mm, mounting shaft 800 a8 (for metric versions),
 mounting shaft 800 a3/8 (for inch versions)

MarTest - Accessories

Styluses
with ruby contact points

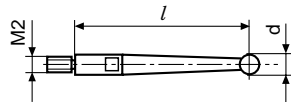

Styluses
with carbide contact points



Spanner for changing the styluses
4305868



Model	Stylus length <i>l</i>	Styluses					
		Cat. no.	Carbide contact point d			Ruby contact point d	
			dia. 1 mm	dia. 2 mm	dia. 3 mm	Cat. no.	dia. 2 mm
800 S/801 S1/801 S 800 SG/801 SG 800 SA 800 SGA 800 SM/801 SM 800 SGM/801 SGM 801 SGE 800 SR/801 SR 800 SRM/801 SRM 800 H/801 H 800 V/801 V 800 VGM/801 VGM	14.5 mm	800 ts	4305870	4305850	4305871	800 tsr	4309051
800 SGE	9.1 mm	800 te	4308851	4308850	4308852	800 ter	4309050
800 SL/801 SL 800 SGL/801 SGL	41.24 mm	800 tl	4306851	4306850	4306853	800 tlr	4309053
800 SGB	32.3 mm	800 tb	4301851	4301850	4301852	800 tbr	4309052

Digital Test Indicator MarTest 800 EW



Features

Functions:

- ON/OFF
 - RESET (Set display to zero)
 - mm/inch
 - MAX/MIN memory
 - MAX-MIN ideal for testing concentricity an flatness
 - Auto-OFF
- Operating and display unit (bezel) can be rotated through 360°
 - Satin chrome finished housing with 3 dovetail guideways
 - Shockproof, movement bearings are jewelled
 - Automatic matching to sensing direction
 - Anti-magnetic
 - Double lever supported in ball bearings, overload protection provided by slip clutch
 - Supplied with: Plastic case, spanner to change the styli, contact point dia. 2 mm, mounting shaft 800a8
- Inductive measuring system, battery life span ca. 2 years
 - MarConnect data output, choose alternatively: USB
OPTO RS232C
 - Operating unit is protected against coolants and lubricants, protection class IP65
 - Combined analog and digital display

Technical Data

	Measuring range		Resolution switchable mm / inch	Measuring force N	Length of styli mm	Order no.
	mm	(inch)				
800 EW	± 0.4	(± .015")	0.001 / .0005" 0.01 / .0005"	0.13	14.5	4305120

Accessories

	Order no.
Styli , with carbide contact point dia. 1 mm	4305870
Styli , with carbide contact point dia. 2 mm	4305850
Styli , with carbide contact point dia. 3 mm	4305871
Styli , with ruby contact point dia. 2 mm	4309051
Battery 3V, Type CR 2032	4102520
Data Connection Cable USB	800 EWu 4305121
Data Connection Cable Opto RS232	800 EWr 4305122

Accessories for Data Processing Chapter 11

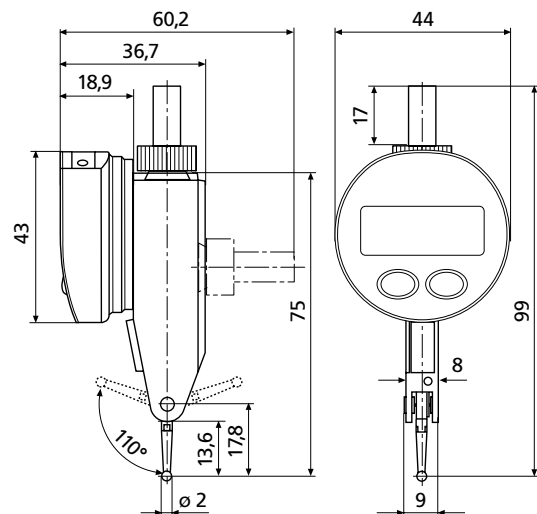

Digital Test Indicator MarTest 800 EWL



Features

Functions:

- ON/OFF
- RESET (Set display to zero)
- mm/inch
- MAX/MIN memory
- MAX-MIN ideal for testing concentricity and flatness
- Auto-OFF
- Inductive measuring system, battery life span ca. 2 years
- MarConnect data output, choose alternatively:
 - USB
 - OPTO RS232C
- Operating unit is protected against coolants and lubricants, protection class IP65
- Combined analog and digital display
- Operating and display unit (bezel) can be rotated through 360°
- Satin chrome finished housing with 3 dovetail guideways
- Shockproof, movement bearings are jewelled
- Automatic matching to sensing direction
- Anti-magnetic
- Double lever supported in ball bearings, overload protection provided by slip clutch
- Supplied with:
 - Plastic case, spanner to change the styli, contact point dia. 2 mm, mounting shaft 800a8

Technical Data

	Measuring range		Resolution switchable mm / inch	Measuring force N	Length of styli mm	Order no.
	mm	(inch)				
800 EWL	± 0.25	(± .010")	0.001 / .0005" 0.01 / .0005"	0.07	41.24	4306120

Accessories

	Order no.
Styli, with carbide contact point dia. 1 mm	4306851
Styli, with carbide contact point dia. 2 mm	4306850
Styli, with carbide contact point dia. 3 mm	4306853
Styli, with ruby contact point dia. 2 mm	4309053
Battery 3V, Type CR 2032	4102520
Data Connection Cable USB	800 EWu 4305121
Data Connection Cable Opto RS232	800 EWr 4305122

Accessories for Data Processing Chapter 11

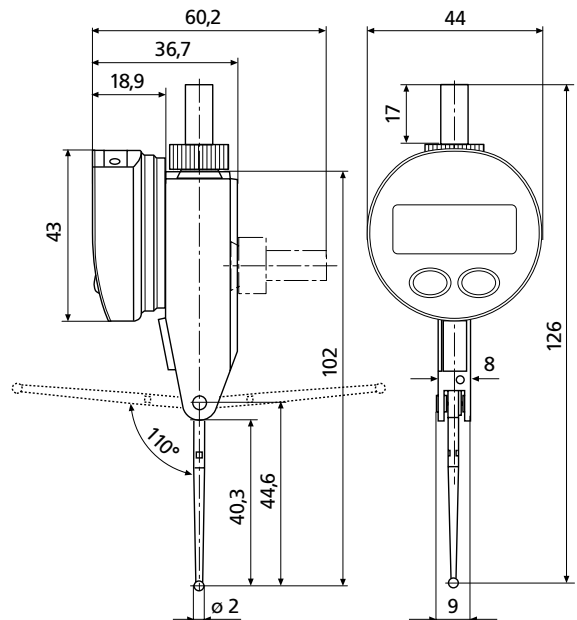

Martest - Accessories

Mounting shaft for dovetail

Mounting shaft	dia. d mm	Order no.
800 a8	8	4305865
800 a6	6	4301865
800 a4	4	4305885
800 a1/4	1/4"	4305895
800 a3/8	3/8"	4305875

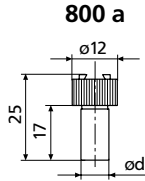

Stand 801 p



- With swivel holder
- Base with V-groove 140°
- Total height 150 mm
- Mounting bore dia. 4 and 8 mm
- Column dia. 8 mm
- Base surface 65 x 40 mm

Order no. 4309090

Indicator not included.

Centering support rods 801 v

- For aligning and centering work pieces on machine tools
- Swivel mounting clamp and fine adjustment
- Stainless steel rods

Mounting bore dia. 8 mm
Swivel range of mounting clamp 180°

Order no. 4309070

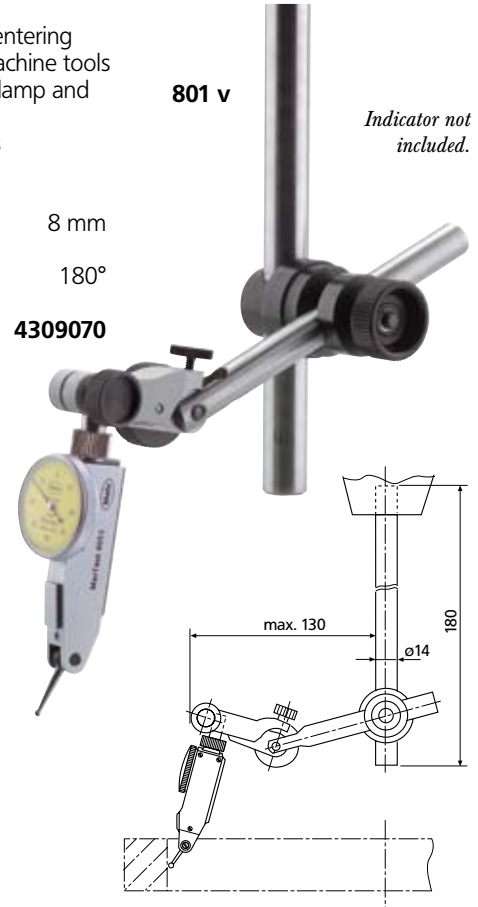

Indicator not included.

Leveling Table TE-20

Cuts set-up time 60% or more for many height gage measurements.

- The leveling table, TE-20, permits you to quickly bring the surface of a part into alignment with a surface plate in both planes. Completely eliminates shimming. Saves so much time that, used only occasionally, it will pay for itself in two weeks.
- The top plate is stress-relieved steel providing about 67 square inches of work area. It is drilled and tapped for fixtures. Fine pitch screws and large knobs assure precisely controlled adjustments. Works with any type of height gage.
- Operation is simple. Height gage readings are taken at edges of the surface to be aligned. Each plate, independently adjustable at right angles to the other, is angled as required for precise alignment.
Flatness = .025 mm / .001"



Typical checks which require careful positioning of work because rest surface is not sufficiently parallel to other work surfaces. Leveling Table compensates for error quickly, drastically reduces set-up time.

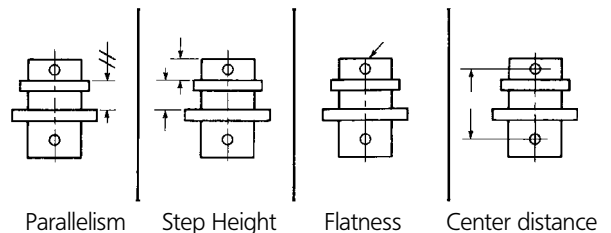

Adjustment	Top Plate	Bottom Plate
Total	± 1° 30'	± 1° 30'

Martest - Accessories

Holder 800 h

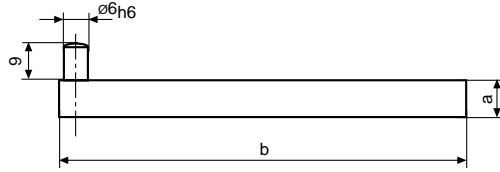

	Dimensions		Order no.
	a	b	
800 h1	9x9	100	4305888
800 h2	1/4" x 1/2"	4"	4305889

Universal clamp 800 k

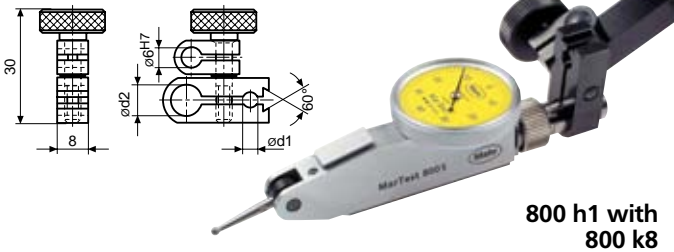

800 h1 with 800 k8

	Dimensions		Order no.
	dia. d1	dia. d2	
800 k8	4	8	4305891
800 k3/8	5/32"	3/8"	4305892

Indicator not included.

Universal centering support frame 800 b Order no. 4305893

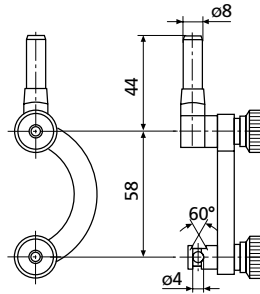

Indicator not included.

Universal holder with dovetail clamp

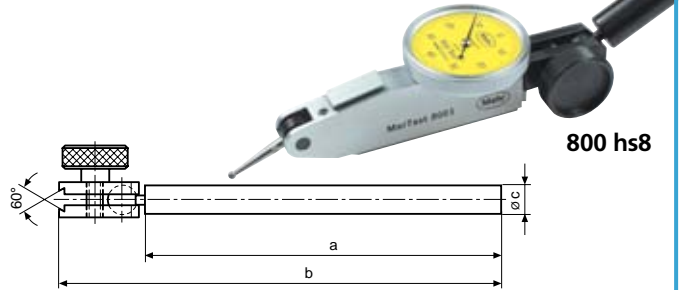

800 hs8

	Dimensions			Order no.
	a	b	dia. c	
800 hs8	100	124	8	4305886
800 hs3/8	4"	5"	3/8"	4305887

Indicator not included.

Ball Clamp

- Dovetail and ball for indicator mounting and omni-directional orientation

Order no. **AT-50**

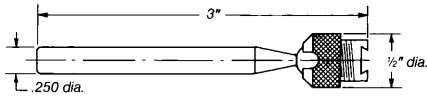

Jig Borer Attachment

- Furnished with two rods and clamp for fast machine mounting

Order no. **RD-21**

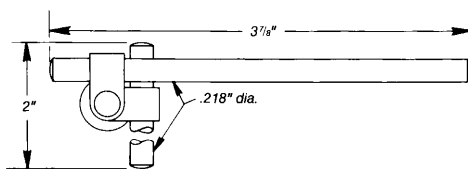

Swivel Clamp

- Normally furnished with MarTest models. Allows indicator to be mounted on most indicator stands and fixtures

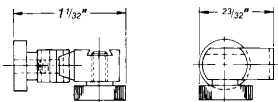

Order no. **CP-2199**

Double-jointed Clamp

- Reaches up to 127 mm / 5" with easy positioning for many applications including milling machine and Jig Borers

Order no. **AT-100**

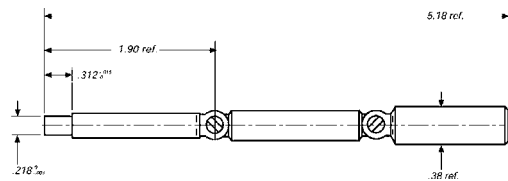

Holding Bar

- Normally furnished with MarTest models. Three-inch length provides ample reach for most applications

Order no. **HB-2157**

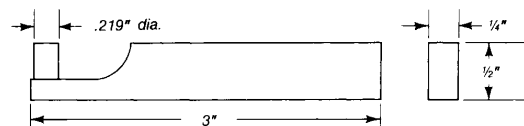

Martest - Accessories

Test Stand 1492B

- Use with any MarTest Indicator - Support arms stepped at one end (.218" dia.) for Swivel Clamp (CP-2199) included.
- Accommodates Vertical and Horizontal lug back mounts for AGD type Indicators.
- Bases have powerful "ON/OFF" permanent magnets which hold from any of four faces - three sides or bottom.



Indicator not included.

Base Dimensions W x L x H		Main Post		Support Arm		Order no.
mm	(inch)	Length mm / inch	Diameter mm / inch	Length mm / inch	Diameter mm / inch	
60 x 48 x 59	(2.4" x 1.9" x 2.2")	178 / 7"	10 / .47"	165 / 6.5"	9.9 / .39"	1492B-5
60 x 48 x 59	(2.4" x 1.9" x 2.2")	178 / 7"	10 / .47"	149 / 5.9"	9.9 / .39"	1492B-10
114 x 48 x 59	(4.5" x 1.9" x 2.2")	401 / 15.8"	20 / .79"	20 / 7.9"	14 / .55"	1492B-15

*Measurements are mm/inch. All models furnished with post clamp and indicator mounting clamp.
Style 1492B-10 has fine adjustment on post clamp.*

Transfer Stand 2300

- Fine adjustment conveniently located in base
- Three-point base pads improve accuracy
- Contoured shape facilitates movement
- Use with any Testmaster Indicator - stud accommodates Swivel Clamp (CP-2199)
- EHE-2048 Gage head requires a CP-116 Clamp



Indicator not included.

Base Dimensions W x L x H		Column (dia. x H)	Maximum vertical capacity	Reach (base to contact point)	Mounting stud dia.	Order no.
mm	(inch)	mm / inch	mm / inch	mm / inch	mm / inch	
76 x 110 x 45	(3 x 4.375 x 1.75")	25 x 430 / .995 x 17"	457 / 18"	approx. 86 / 3.375"	5.55 / .218"	2300

Mechanical 3D-Touch Probe MarTest 802 NW

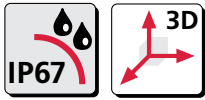

Applications

Can be used on milling and CNC machines to

- determine the zero position on a work piece
- determine the center of a bore
- determine and correct the position of a work piece

and for measurement of

- lengths
- depths

Features

- High accuracy and linearity
 - suitable for measuring work pieces
 - measurement over the entire working range is possible
- Can be controlled independently of a machine tool
- Easy to read display
- Large working range in all axis (X, Y, Z) prevents damage to the stylus by contacting errors
- Shock and Water proof, ideal for the use on a machine with a tool changer
- Compact metal housing and long probe arm
- Supplied with: Styli 802 EWt and operating instructions

Technical Data

	Repeatability in zero position unidirectional	Readings	Dial dia.	Mounting shaft dia.	Order no.
802 NW	± 0.01 mm	0.01 mm	50 mm	16 mm	4304311

Accessories

Styli	dia. d mm	l mm	Order no.
802 EWt	4	31	4304320
802 NWt	6	56.6	4304321

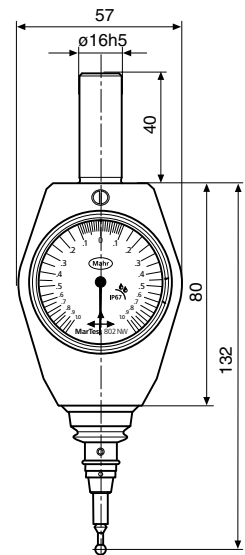
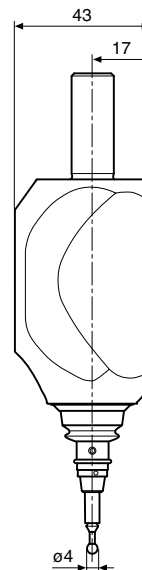
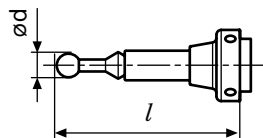

Digital 3D-Touch Probe MarTest 802 EW



Applications

Can be used on milling and CNC machines to

- determine the zero position on a work piece
- determine the center of a bore
- determine and correct the position of a work piece

and for measurement of

- lengths
- depths

Features

- High accuracy and linearity
 - suitable for measuring work pieces
 - measurement over the entire working range is possible
- Can be controlled independently of a machine tool
- Easy to read display due to the combination of:
 - a progressive analog display (bar graph) for dynamic path information
 - a digital display for accurate reading
- Large working range (6 mm) in all axis (X, Y, Z) prevents damage to the stylus by contacting errors
- Shock and water proof; ideal for the use on a machine with a tool changer
- Compact metal housing and long probe arm
- Supplied with:
 - Styli 802 EWt, battery and operating instructions

Technical Data

	Working range X, Y, Z-Axis	Repeatability in zero position unidirectional	Resolution of digital display	Display range	Mounting shaft dia.	Order no.
802 EW	-2 to 4 mm	± 0.005 mm	0.005 mm	± 2 mm	16 mm	4304300
802 EWZ	-.0787" to .157"	± .0001"	.0001"	± .0787"	3/4"	4304305

Accessories

Styli	dia. d mm	l mm	Order no.
802 EWt	4	31	4304320

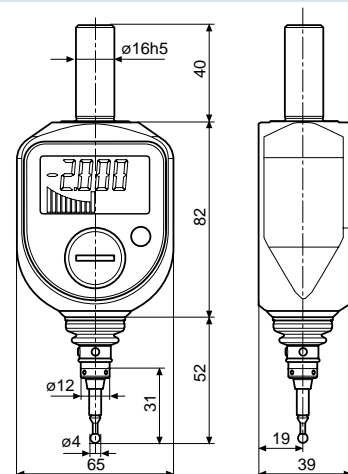
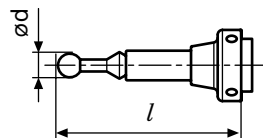

WWW.MAHR.COM

- 0 +

Mahr

E X A C T L Y



آزما صنعت گراد

تست و اندازه گیری . تجهیزات . مشاوره

Unit 3 - 2ndfloor- No.24 West Shahid Ghandi St.
North Sohrevardi Ave. Tehran . Iran
Tel : +98 21 88745209 , 86030765
Fax: +98 21 88764890

تهران - خیابان سهروردی شمالی - خیابان شهید قندی غربی
پلاک ۲۴ - ورودی غربی - طبقه دوم - واحد ۳
تلفن : ۸۶۰۳۰۷۶۵ ، ۸۸۷۴۵۲۰۹
فاکس : ۸۸۷۶۴۸۹۰

www.asgradco.com info@asgradco.com