

# Multicomponent Force Plate

Type 9285BA

## with Glass Top Plate for Biomechanics, $F_z$ 0 ... 10 kN

Multicomponent force plate with glass top plate for measuring ground reaction forces, moments and the center of pressure in biomechanics.

- Glass top plate allows recording of contact surface
- Wide measuring range
- Excellent measuring accuracy
- Good accuracy of center of pressure (COP)
- Threshold  $F_z < 250$  mN

### Description

Multicomponent force plate Type 9285BA consists of a base frame on which four piezoelectric 3-component force sensors under a high preload are mounted. A 600x400 mm triple-layer composite glass plate is mounted on these sensors. The very low crosstalk values of the sensors in conjunction with the special design principle ensure very good accuracy of the center of pressure. Type 9285BA has a built-in charge amplifier compatible with all of the common motion analysis systems.

### Application

This force plate is designed for special gait and balance analysis applications. The glass plate allows simultaneous force measurement and photographic or cinematographic recording of the contact surface from below. Despite the wide measuring range (0 ... 10 kN), this force plate offers excellent accuracy and linearity across the entire spectrum of applications and guarantees overload protection up to 12 kN. A larger force plate with external dimensions of 900x600 mm is available on request.

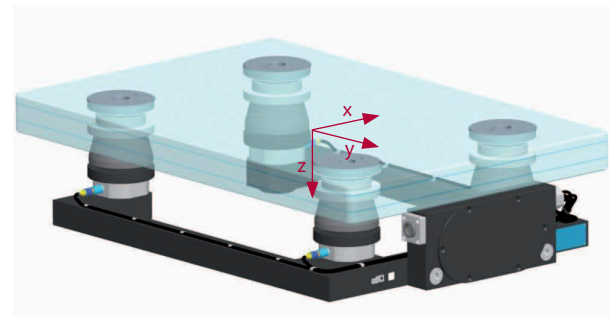

### Technical Data

Dimensions		mm	600x400x150,4
Range	$F_x, F_y$	kN	-2,5 ... 2,5
	$F_z$	kN	0 ... 10
Overload	$F_x, F_y$	kN	-6/6
	$F_z$	kN	0/12
Linearity	%FSO		$\leq \pm 0,5$
Hysteresis	%FSO		$\leq 0,5$
Crosstalk	$F_x \leftrightarrow F_y$	%	$< \pm 2$
	$F_x, F_y \rightarrow F_z$	%	$< \pm 2$
	$F_z \rightarrow F_x, F_y$	%	$< \pm 0,5$
Rigidity	x-axis ( $a_y = 0$ )	N/ $\mu$ m	$\approx 120$
	y-axis ( $a_x = 0$ )	N/ $\mu$ m	$\approx 115$
	z-axis ( $a_x = a_y = 0$ )	N/ $\mu$ m	$\approx 25$
Natural frequency	$f_n(x, y)$	Hz	$\approx 300$
	$f_n(z)$	Hz	$\approx 500$
Operating temperature range		$^{\circ}$ C	0 ... 60
Weight		kg	45
Degree of protection	EN 60529:1992		IP65
Refractive index of glass top plate		n	$\approx 1,52$

**Technical Data (Cont.)**

**Force Plate with Built-in 8-Channel Charge Amplifier  
(4 Measuring Ranges)**

Calibrated partial range	$F_x, F_y$	kN	0 ... 0,25
	$F_z$	kN	0 ... 1
Calibrated range	$F_x, F_y$	kN	0 ... 1,25
	$F_z$	kN	0 ... 5
Sensitivity range 1	$F_{xi}, F_{yi}$	mV/N	≈37,5
	$F_{zi}$	mV/N	≈19,0
Sensitivity range 2	$F_{xi}, F_{yi}$	mV/N	≈7,5
	$F_{zi}$	mV/N	≈3,8
Sensitivity range 3	$F_{xi}, F_{yi}$	mV/N	≈3,8
	$F_{zi}$	mV/N	≈1,9
Sensitivity range 4	$F_{xi}, F_{yi}$	mV/N	≈1,9
	$F_{zi}$	mV/N	≈0,9

Ratio range	1:2:3:4		1:5:10:20 <sup>1)</sup>
Threshold		mN	<250 <sup>2)</sup>
Drift	$F_x, F_y$	mN/s	<5
	$F_z$	mN/s	<10
Supply voltage		VDC	10 ... 30
Supply current		mA	≈45
Output voltage		V	0 ... ±5
Output current		mA	-2 ... 2
Control inputs (optocoupler)		V	5 ... 45
		mA	0,4 ... 4,4

<sup>1)</sup> ±0,5 % accuracy  
<sup>2)</sup> range 1 only

Conforms to the **CE** safety standards (73/23/EG) for electrical equipment and systems: EN 60601-1:2005, EN 61010-1:2001 and the EMC standards (89/336/EG): EN 60601-1:2005 (EN 55022 Class B), EN 61000-6-3:2004 (EN 55022 Class B), EN 61000-6-4:2001 (EN 55011 Class B), EN 60601-1:2005, EN 61000-6-1:2001, EN 61000-6-2:2005.

**Dimensions**

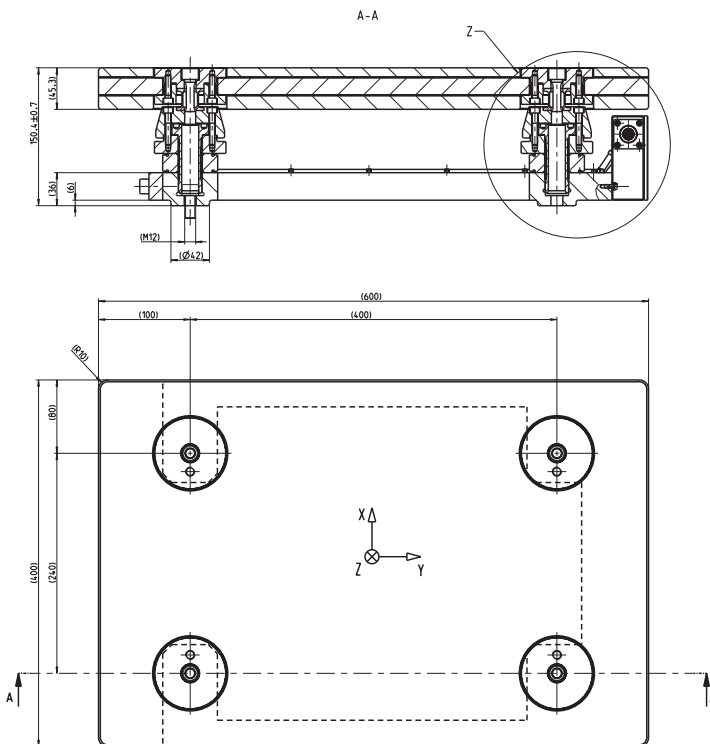

Fig. 2: This photograph taken through the glass plate from below shows the main part of the standing phase of a step

Fig. 1: Dimensions of multicomponent force plate Type 9285BA

9285BA\_000-743e-02\_10

**Typical Measuring Chains**





			
Multicomponent force plate with charge amplifier Type 9285BA	Connection cable Type 1758A...	DAQ system (USB 2.0) Type 5691A1	Laptop (provided by customer) with BioWare

Fig. 3: Configuration of a typical measuring chain with Kistler DAQ system BioWare®

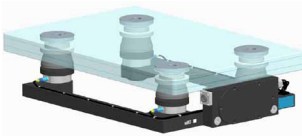

			Ch 1 = F <sub>x</sub> 1+2    Ch 5 = F <sub>z</sub> 1 Ch 2 = F <sub>x</sub> 3+4    Ch 6 = F <sub>z</sub> 2 Ch 3 = F <sub>y</sub> 1+4    Ch 7 = F <sub>z</sub> 3 Ch 4 = F <sub>y</sub> 2+3    Ch 8 = F <sub>z</sub> 4
Multicomponent force plate with charge amplifier Type 9285BA	Connection cable Type 1760A...	External Control Unit (8xBNC fem.) Type 5233A2	DAQ system provided by customer (8 analog channels)

Fig. 4: Configuration of a typical measuring chain with DAQ system provided by customer

**Included Accessories**

- 1 Set shims
- 4 Hexagon socket head cap screws M12x25
- 1 Hexagon socket wrench
- 4 Eye bolts M10 (DIN 580)
- 1 Sylgard 170 A&B Elastomer
- 1 Voltage equalizing cable

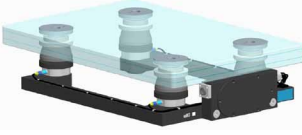
**Type/Art. No.**

- 7.050.011
- 6.120.106
- 1391
- 6.170.025
- 6.921.001
- 5.590.175

**Ordering Code**

- Multicomponent force plate with charge output

**Type 9285BA**

**Optional Accessories**

- Connection cable:  
Force plate → BioWare
- DAQ system BioWare
- Connection cable:  
Force plate → Control Unit
- Remote Control Unit
- Mounting frame

**Type/Art. No.**

- 1758A5,  
1758A10,  
1758Asp
- 5691A1 or  
2812A...
- 1760A5,  
1760A10,  
1760Asp
- 5233A2
- Z12627

9285BA\_000-743e-02\_10